

President: Mike Basta
913-492-4830
Vice President: Dana Field
913-400-2132
Treasurer: Jack Vetter
913-296-5224
Secretary: Roie Black
512-731-5873
Newsletter Editor: Dana Field
913-400-2132
Website Editor: Jeff Nisley
913-406-1331



AMA Charter # 2357
SAM Chapter #14
FAC Squadron 43

Heart of America Free Flight Association



Dispatch



Website – KCFreeflight.org



Schedule of Flying Events and Meetings

April 2023

Date	Day	Location	Time	Notes
INDOOR EVENTS				
May 16	Tues	Overland Park, KS	7:00 pm	HAFFA Monthly Meeting
June 20	Tues	Overland Park, KS	7:00 pm	HAFFA Monthly Meeting
July 18	Tues	Overland Park, KS	7:00 pm	HAFFA Monthly Meeting
August 15	Tues	Overland Park, KS	7:00 pm	HAFFA Monthly Meeting
September 19	Tues	Overland Park, KS	7:00 pm	HAFFA Monthly Meeting
Outdoor Events				
May 23	Tues	Olathe, KS	6:30 pm	HAFFA Outdoor Champs Flying
June 13	Tues	Olathe, KS	6:30 pm	HAFFA Outdoor Champs Flying
June 27	Tues	Olathe, KS	6:30 pm	HAFFA Outdoor Champs Flying
July 11	Tues	Olathe, KS	6:30 pm	HAFFA Outdoor Champs Flying
July 25	Tues	Olathe, KS	6:30 pm	HAFFA Outdoor Champs Flying
August 8	Tues	Olathe, KS	6:30 pm	HAFFA Outdoor Champs Flying
August 22	Tues	Olathe, KS	6:30 pm	HAFFA Outdoor Champs Flying
Sept 2, 3, & 4	Sat – Mon	Denver, CO	All days long	MMM Rocky Mt. Championships
Sept 12	Tues	Olathe, KS	6:00 pm	Final 2023 Outdoor Champs Flying Day
Sept 24	Sun	Perry, KS	12:00 - ?	HAFFA Annual Picnic
Oct 1 & 2	Sat & Sun	Marion, KS	All Day – Both Days	HAFFA Annual Out Door Contest

Flying Sites

Indoor

Osawatomie City Auditorium
437 Main St.
Osawatomie, KS 66047

Outdoor

Carmel Farm
2831 Oak St.
Perry, KS 66673

Editorial — It has been a long time since I got a newsletter out for a variety of reasons, and this one originally had January as the header, then February, then March, and finally April. I know it is now May, but I intend to cover everything from January through our indoor contest in April, here and get out a second May issue covering the start of outdoor. I admit there is some burn out, along with a case of Covid 19, and some other issues that have delayed me as well. Any volunteers to take this over? In February, we had the annual HAFFA dinner at Conroy's Public House in Overland Park. Food was great, and a great time was had! Joe Francesco made the trip up from Fulton Missouri. Good to see him again! A bunch of us also went to the KCRC Swap meet. It is held the first Saturday in February, so our flying was delayed a week so we could go.

Indoor — We had a great indoor season, with a few more flyers than last year. It was nice to see Gary Hodson there every month, and as usual, he could stomp all of us rank amateurs in any event he wanted to fly. His advice and willingness to tutor anyone wanting help is a great benefit of his presence. So, following is Jeff Renz's write up on our contest, and a number of pictures from the season and contest, from the Science Olympiad at JCCC, and from the KCRC Swap Meet. Jeff Renz's Indoor Column and contest results below:

APRIL 15, 2023 HAFFA INDOOR SESSION RESULTS FROM TODAY

We had a great turnout today for our last indoor flying session, including John Clark, Dana Field, Roie and Cheryl Black, Mike Schmidt, Jack Vetter, Gary Hodson, Paul Morganroth, and Jeff Nisley. Mike Schmidt's family also showed up along with his new grandson. We also had 4 guests....2 locals and 2 tourists from Chicago that were walking around downtown Osawatomie and had happened to stop in to see what we were doing. They were all amazed. We also had a Science Olympiad flyer and his dad come to the auditorium to fly the "AMA Penny Plane" they had built under the instruction of Paul. It was a very well built plane and is surely capable of 10 minutes. Jeff Nisley had the eight P18's from our "STARS" program all assembled and waiting, sitting on a table. We did not plan for visitors, but we ended up having some. How crazy is that? Jeff Renz handed the visitors the P18s with motors, and we had the biggest mass launch in club history with a total of 8 fliers. It was awesome!!! Dana Field and Mike Schmidt duked it out for the last man down. Schmidt prevailed. (editor's comment, Mike Schmidt's video showed that I actually by a fraction of a second won!) Contact with the guests was established and addresses for the Chicago Aeronuts was established/explained. The local husband and wife team might end up joining our club.

Jeff Nisley flew his new Howard Littman design, "Bostolation", which has 3 vertical fins like the "CONSTELLATION". It flew right off the board! Paul was able to get several decent flights of the 5 cent "Comet CESSNA" that was built by Nisley. Jack Vetter got some very good flights with his Phantom Flash. It looked really great in the air. Dana managed a 21 second indoor glider flight with his Super Cat's Meow glider which is a club record (NO!! Tem Johnson got 34 seconds at Osawatomie, cannot consider records less than that)) since Tem Johnson passed on some years ago. Gary Hodson put in a 5 and a half minute flight with his A6 which was quite amazing. There were other highlights as well. Roie Black found his "STARS" P18 which he built a while back and put in some great P18 flights. Mike Schmidt was able to give several demo flights with his well made airplanes for his family members.

I would like to thank Cheryl and Roie for timing the events today. Cheryl had her hands full keeping the stop watch going all day! Thanks so much Cheryl! We appreciate you!

I will send a score report later with more details.

A great time was had by all to wrap up our indoor year for 2023! I would like to thank everyone for their support keeping indoor flying alive and well this year.

Thanks
Jeff Renz

2023 Intra-Club Indoor Contest Score Results

	<u>Nov.</u>	<u>Dec.</u>	<u>Jan.</u>	<u>Feb.</u>	<u>Mar.</u>	<u>Apr.</u>	<u>Totals</u>
J. Renz	10	9	9	0	12	15	55
D. Field	9	7	0	6	9	15	46
G. Hodson	6	7	2	2	6	4	27
R. Black	3	0	0	1	0	4	8
J. Nisley	1	3	5	3	3	6	21
M. Schmidt	0	0	0	0	11	10	21
J. Vetter	0	0	3	0	2	2	7

2023 Intra-Club Winners – 1st Place – Jeff Renz
2nd Place – Dana Field
3rd Place – Gary Hodson

2023 HAFFA Indoor Club Contest Results

April 15 Raw Scores for 1st, 2nd, & 3rd

	<u>Glider</u>	<u>Jet Cat</u>	<u>NOCAL</u>	<u>A-6</u>	<u>5 Cent</u>	<u>P-18</u>	<u>Total</u>
J. Renz	3	2	4	1	0	5	15
D. Field	4	1	3	0	1	6	15
J. Nisley	2	0	2	0	0	2	6
R. Black	0	0	0	0	0	4	4
J. Vetter	1	0	0	0	0	1	2
G. Hodson	0	0	1	3	0	0	4
M. Schmidt	0	0	5	2	0	3	10

2023 HAFFA Indoor Contest Winners - 1st Place Tie – Dana Field & Jeff Renz
3rd Place - Mike Schmidt

2023 Tem Johnson Indoor Glider Award

	<u>Nov.</u>	<u>Dec.</u>	<u>Jan.</u>	<u>Feb.</u>	<u>Mar.</u>	<u>Apr.</u>	<u>Total</u>
J. Renz	1	1	2	0	3	3	10
D. Field	3	2	0	2	2	4	13
R. Black	2	0	0	1	0	0	3
J. Nisley	0	0	0	0	0	2	2
J. Vetter	0	0	1	0	1	1	3

2023 Tem Johnson Indoor Glider Winners - 1st Place – Dana Field
2nd Place - Jeff Renz
2rd Place Tie – Roie Black & Jack Vetter



Suman Sarapalli, Paul Morganroth, Dennis Baker, Dana Field, and Jeff Renz at the KCRC Swap Meet.. It is held at John Knox Village, and has a mind blowing selection of everything & some great prices. Charlie & Liz did not make this picture.



Suman weighing a team's model



A team getting ready to launch



Suman, Paul, and Jeff Renz at the Science Olympiad, with a Honeywell assisting person



Roie Black presenting the 2023 Indoor Championship Trophy to Jeff Renz



Jeff Renz presenting the Tem Johnson Glider Champion Trophy to Dana Field

Outdoor – Indoor has ended for us until October, and outdoor has begun, sort of. In April we have practice flying sessions the second and fourth Tues. of the month. So the second Tuesday I got to the field in Olathe at 6:15, 15 minutes early. I waited until 7:00, and no one else showed up! Weather you say? It was 80 degrees, and the slight breeze of 5 to 8 from the SSE faded to close to zero by 6:30. The air was light and buoyant, maybe the best weather we have ever had! And, no one was there to fly! We did a little better on the fourth

Tuesday, and flying for real (points begins in May. Just a brief reminder, all of the flying is scheduled for the second and fourth Tuesdays of the month through the second Tuesday in Sept. (check the calendar), and make up for a rain out/blow out the Thursday of the same week. And, a reminder, the four events include Combined AMA HLG/CLG, FAI Jet Cat, FAI Blue Ridge Special, and Combined ½ Gollywock/ ½ Wakefield. There is also a separate event for SAM Old Time Glider. Hope to see a bunch more of you at the next session.

A Few Pictures From Flying Sessions and Pretty Airplanes

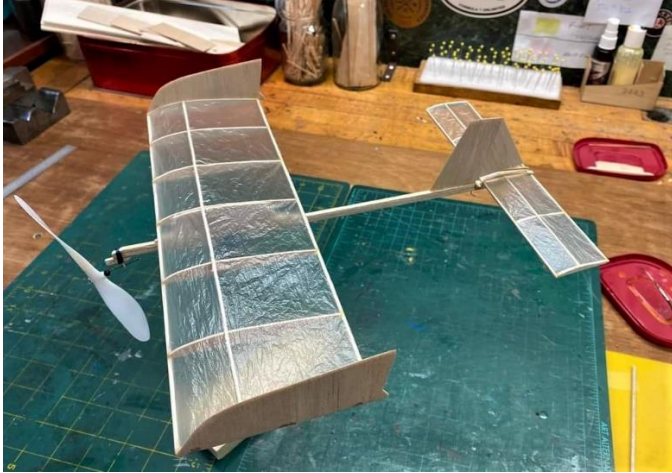

Baltimore Clipper – did not get to whom it belongs



Charlie Taylor & Liz Besser at KCRC Swap Meet



Emil Schutzel, we lost him this last winter, winding his Bostonian. He kicked butt in this event as well!

Plans – The plan is a reprint of the FAI Blue Ridge Special, an event in the Outdoor Champs. It is a simple stick build, not taking very long, and it really flies well. Flies OOS down in Marion! Should see a few of these.

THE BLUE RIDGE SPECIAL

A HIGH FLYING RUBBER POWERED MODEL
 BY BLUE RIDGE MODELS
 ASHEVILLE, NORTH CAROLINA

Copyright 1977 all rights reserved

unt and inci-
 trip are from
 /8" spruce.
 gether.

NOTE: DO NOT GLUE WING MOUNT TO MOTOR STICK.
 Wing slides on motor stick for adjustment.

Rear motor hook. Bind
 with thread and glue.

Block up one wing panel
 together for dihedral
 2 1/2" and glue panels
 before covering.

anel flat on plan.

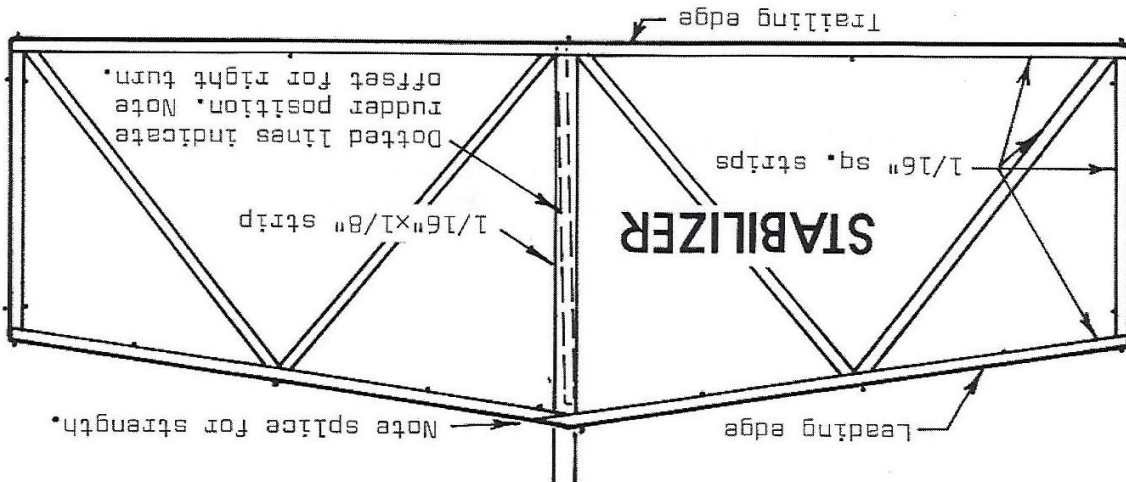
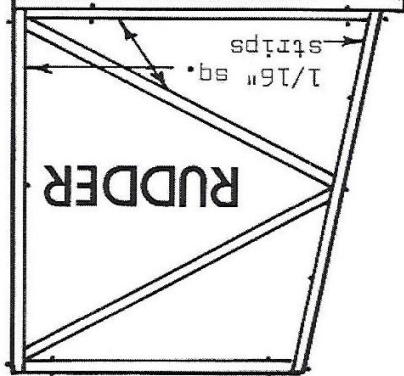
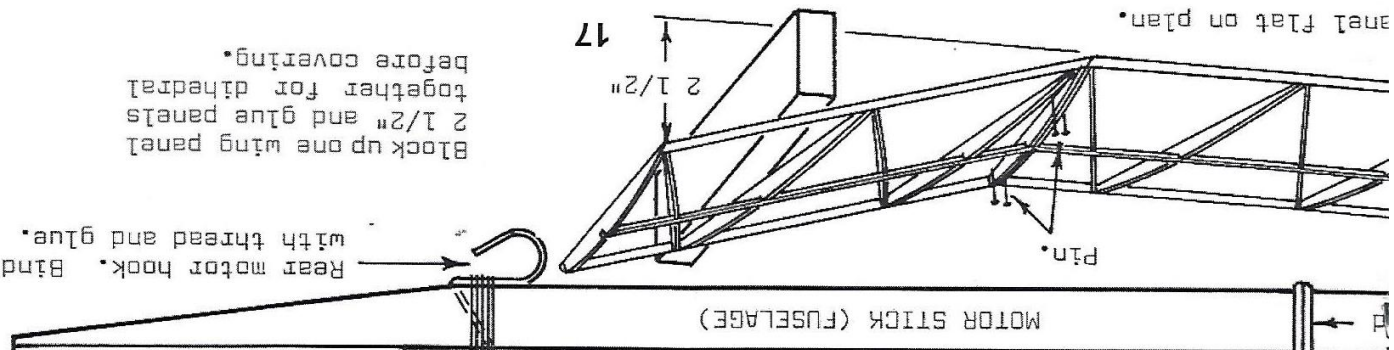

Leading and trail-
 ing flush with rib.

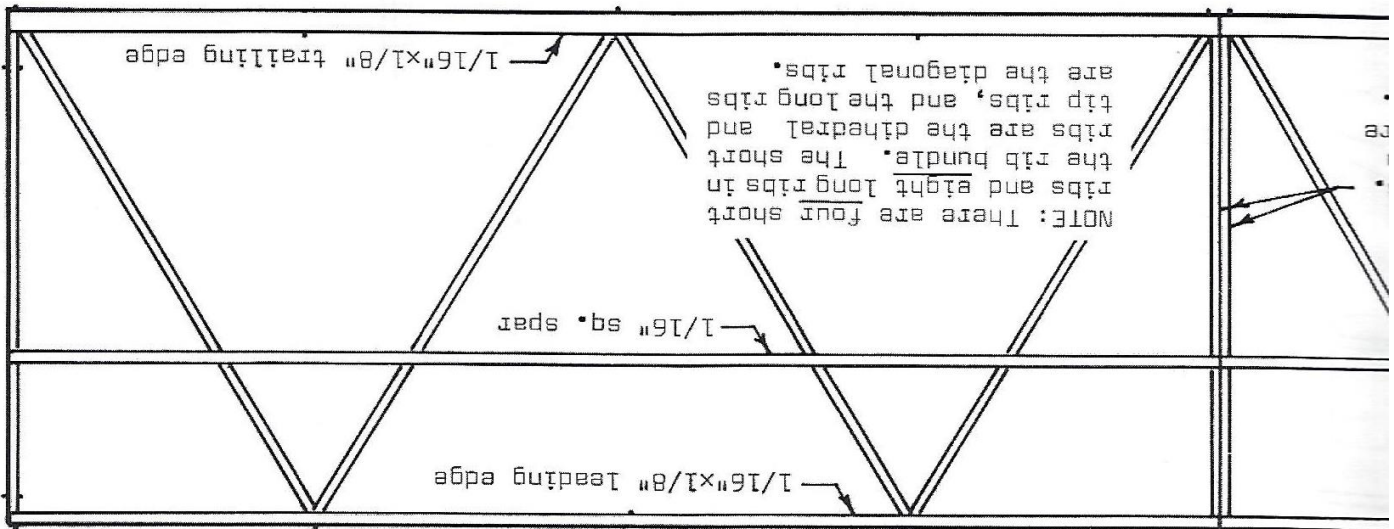

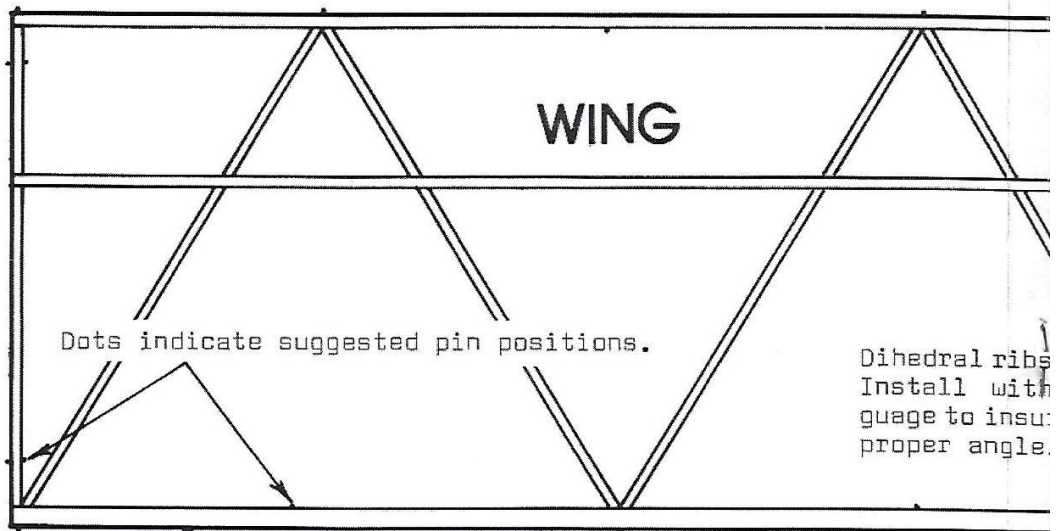
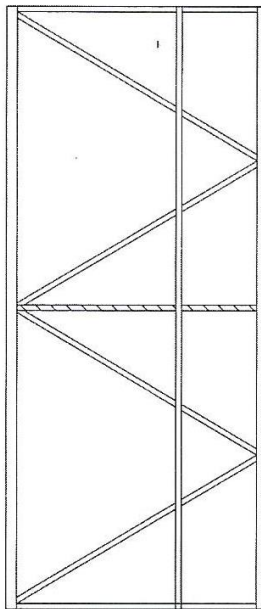

Dihedral ribs
Install with
guage to insu:
proper angle.

REVISED WING WITH
EXTRA VERICAL WING RIB
TO REINFORCE THE
LEADING EDGE AND
IMPROVE AIRFOIL

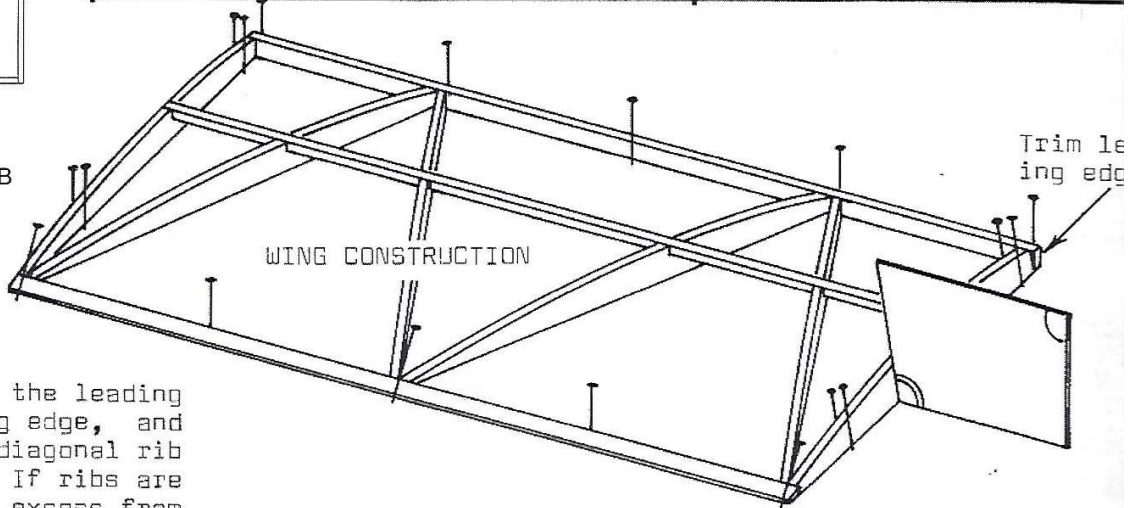

Carefully trim the leading
edge, trailing edge, and
notch of each diagonal rib
to fit snugly. If ribs are
too long, trim excess from
the back. USE A SHARP RA-
ZOR BLADE!!

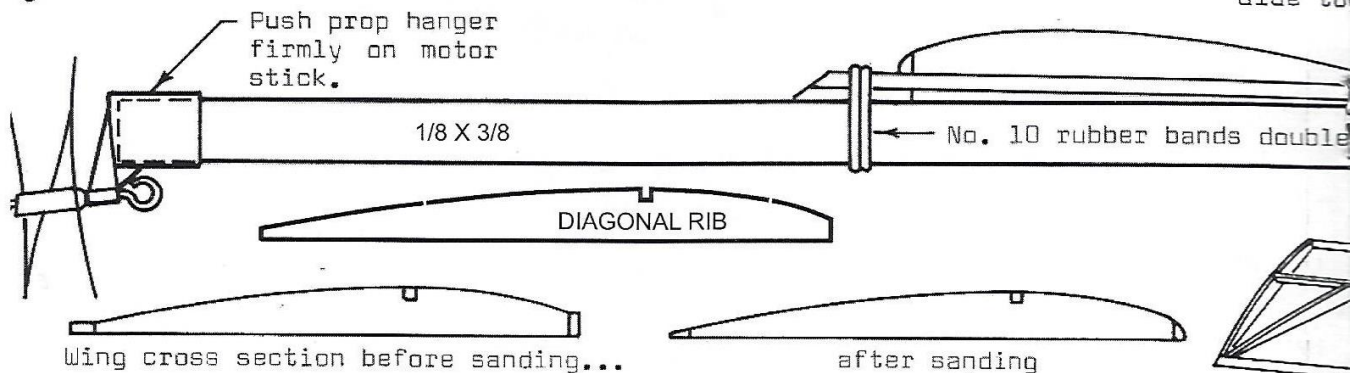
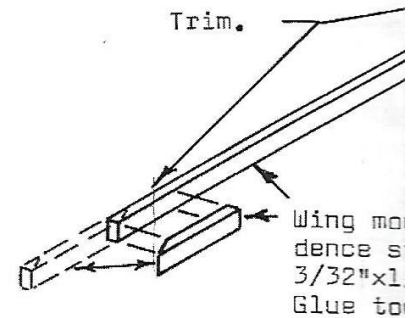
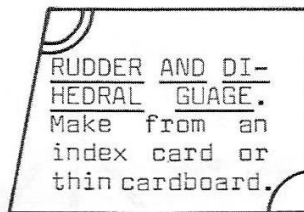
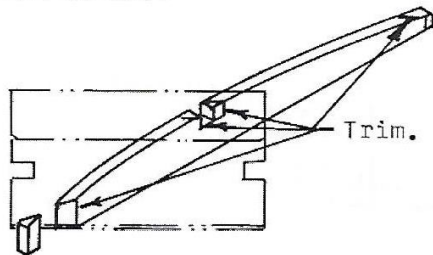

Wing should measure 20". Blow up until the half on pg 1 measures exactly 10 inches, then trace the ribs and build the Horiz. & Vert. over the plan. Is a simple build. Wings build in 2 halves, then glue together. No cutting.