

President: Mike Basta  
 913-492-4830  
 Vice President: Dana Field  
 913-400-2132  
 Treasurer: Jack Vetter  
 913-296-5224  
 Secretary: Roie Black  
 512-731-5873  
 Newsletter Editor: Dana Field  
 913-400-2132  
 Website Editor: Jeff Nisley  
 913-406-1331



AMA Charter # 2357  
 SAM Chapter #14  
 FAC Squadron 43

# Heart of America Free Flight Association

# Dispatch



Website – [KCFreeflight.org](http://KCFreeflight.org)



## Schedule of Flying Events and Meetings

## September 2023

Date	Day	Location	Time	Notes
<b>INDOOR EVENTS</b>				
September 19	Tues	Prairie Village, KS	6:00 pm	HAFFA Monthly Meeting
October 7	Sat	Osawatomie, KS	8:30 – 3:00	1 <sup>st</sup> Day of Indoor Flying
October 17	Tues	?????	6:00 pm	HAFFA Monthly Meeting
November 5	Sat	Osawatomie, KS	8:30 – 3:00	Indoor Flying
November 21	Tues	?????	6:00 pm	HAFFA Monthly Meeting
December 3	Sat	Osawatomie, KS	8:30 – 3:00	Indoor Flying
December 19	Tues	?????	6:00 pm	HAFFA Monthly Meeting
<b>Outdoor Events</b>				
Sept 12	Tues	Olathe, KS	6:00 pm	Final 2023 Outdoor Champs Flying Day
Oct 8?	Sun	Perry, KS	12:00 - ?	Tentative HAFFA Annual Picnic
Sept 30 & Oct 1	Sat & Sun	Marion, KS	All Day – Both Days	HAFFA Annual Out Door Contest

### Flying Sites

#### Indoor

Osawatomie City Auditorium  
 437 Main St.  
 Osawatomie, KS 66047

#### Outdoor

Carmel Farm  
 2831 Oak St.  
 Perry, KS 66673

Frontier Trail Middle School  
 143<sup>rd</sup> St at S. Black Bob Rd.  
 Olathe, KS

**Editorial** – Another newsletter late in going out. This time a virus attack on my computer that kept me out of action for a while.

A couple of changes on the calendar to note. We have a meeting scheduled for next Tuesday, Sept. 12 at the Corinth JC Library on Mission Rd. in Prairie Village. After that we currently do not have a meeting site. Neither

the Corinth nor the Cedar-Roe libraries are available. I have submitted a booking at the Central Resource Library on 87<sup>th</sup> St. near I-35 in Overland Park for a 10 person conference room, but as of now have not had a confirmation. Will of course let you when I have a reply.

Next, the annual picnic at Suman's Carmel Farm is postponed because Suman will be in India to see his ailing mother. He has said we could go ahead without him, making setup difficult, or postpone it until October. I have put Oct. 8<sup>th</sup> on the calendar as a possible date, which is the Sunday after our contest in Marion. Watch for that as well.

Local outdoor flying is done for this year and indoor is approaching, starting next month. I must get building, 2 new planes in the mix this year! And with that \_\_\_\_\_ :

**Indoor** – Our schedule for the indoor season is set, beginning with Oct 7, the first Saturday in Oct, and continuing with the first Saturday of the month through April. Jeff Renz has sent out emails with his choices for the 23-24 indoor season, but just in case you don't have it (there was confusion and changes), it is as follows: A-6, P-18, NoCal, Howard Littman's "Skinny Bomber", and finally the "Baby ROG". There is also indoor combined CLG/HLG for the Tem Johnson Memorial award, but I am not sure if this counts in the point total for the indoor championship. So five rubber events, with two new ones you need to build for, and a glider event. You know, it never rains or blows out an indoor session! Occasionally, the roads are snowy, but not so bad, So, get building! Time is short!

While on the building subject, the plan in this newsletter is the "Baby ROG". One of the things damaged in my computer trials is my ability to manipulate images, and I have not got it fully recovered. I did my best to get a full sized plan in this issue, but what you have is slightly under sized. If you can blow it up yourself, great. If not, our president, Roie Black, who has an 11 x 17 printer, has it redone full size on 11 x 17. If I had been able, you would have had two 8½x11 pages to tape together. I think if you ask Roie for a print, one would be forthcoming.

**Outdoor** – Our HAFFA Outdoor Championship season has come to an end, and despite not flying in May or September, Mike Basta managed to kick butt, and won both the club championship and the Thermic Glider award. I was only able to fly in August and September, and Jeff Renz missed September, but like I said, Mike kicked butt and it would not have mattered. Our congratulations to Mike! Trophies will be handed out at tomorrow night's meeting if Mike can make it. The final standings are at the back of the newsletter.

Our annual outdoor contest at Marion, KS, is now less than two weeks away. Last I knew, there were still a few rooms left at the Country Inn. If you have not been to one of these, they are a lot of fun! So think about coming down to Marion, even if it is only for the day.

Following are a few pictures from recent flying sessions:



Jack Vetter launches a Jet Cat



Mike Schmidt with a new 1/2 Gollywock



Paul Morganroth with one of the new \$4.00 foam gliders. \$4.00, and the way they fly is amazing! These are being sold at places like Hobby Lobby. Get one for a kid, and maybe we will have a new free flyer?



Dennis Baker launches a CLG



Mike's stash, a new 1/2 Gollywock, a Blue Ridge Special, and a Jet Cat, all fly well!

**Plans** – The plan, the Baby ROG, as discussed above.

## HAFFA 2023 Outdoor Club Contest Results/Final Standings

<u>Thermic/OT HLG</u>	May	June	July	August	September	Pt Mth - Tot Pt
Jeff Renz	12	17	-----	5	-----	0 - 4
Mike Basta	-----	8	9	8	-----	0 - 6
Jeff Nisley	-----	-----	9	-----	11	2 - 4
Dana Field	-----	-----	-----	7	3	1 - 3

<u>AMA HLG/CL</u>	May	June	July	August	September	Pt Mth - Tot Pt
Jeff Renz	16	28	-----	25	-----	0 - 6
Mike Basta	28	43	16	26	-----	0 - 10
Mike Schmidt	34	25	27	58	21	3 - 18
Jeff Nisley	7	8	-----	6	3	1 - 4
Dana Field	-----	-----	-----	38	24	4 - 8
Dennis Baker	-----	-----	-----	-----	18	2 - 2

<u>FAC Jet CLG</u>	May	June	July	August	September	Pt Mth - Tot Pt
Mike Basta	21	17	13	14	-----	3 - 6
Jeff Renz	-----	12	-----	-----	-----	0 - 1
Dana Field	-----	-----	-----	4	3	1 - 1
Mike Schmidt	-----	-----	-----	9	12	2 - 2

<u>Blue Ridge Special</u>	May	June	July	August	September	Pt Mth - TotPt
Mike Basta	64	59	71	61	-----	0 - 16
Jeff Renz	33	39	-----	29	-----	0 - 4
Jeff Nisley	36	39	25	30	50	3 - 10
Mike Schmidt	40	57	33	50	36	1 - 15
Dana Field	-----	-----	-----	52	45	2 - 7
Jack Vetter	-----	-----	-----	11	-----	0 - 1

<u>½ Wake/½ Gollywock</u>	May	June	July	August	September	Pt Mth - TotPt
Mike Basta	25	37	47	44	-----	0 - 8
Jeff Renz	23	16	-----	27	-----	0 - 6
Jeff Nisley	31	8	-----	24	-----	0 - 5
Mike Schmidt	-----	-----	-----	-----	3	1 - 1

<u>Standings</u>	May Pts	June Pts	July Pts	Aug Pts	Sept Pts	Tot Pts	Standings
Jeff Renz	5	8	0	5	-----	18	4 <sup>th</sup>
Mike Basta	10	12	10	15	-----	47	1 <sup>st</sup>
Jeff Nisley	6	3	3	5	4	19	3 <sup>rd</sup>
Mike Schmidt	7	8	4	11	7	37	2 <sup>nd</sup>
Dana Field	-----	-----	-----	10	7	17	5 <sup>th</sup>
Jack Vetter	-----	-----	-----	1	-----	1	6 <sup>th</sup>
Dennis Baker	-----	-----	-----	-----	1	1	6 <sup>th</sup>

\*Thermic/Old Time points do not count toward HAFFA Club Champion  
Old Time Thermic Champion is a separate award.

**COVERING HINTS**  
 CUT TISSUE SLIGHTLY LARGER THAN PANEL BEING COVERED. IT IS ONLY NECESSARY TO HAVE TISSUE STICK TO OUTER EDGES OF FRAMEWORK. BANANA LIQUID MAY BE USED FOR AN ADHESIVE INSTEAD OF GLUE, IF DESIRED.

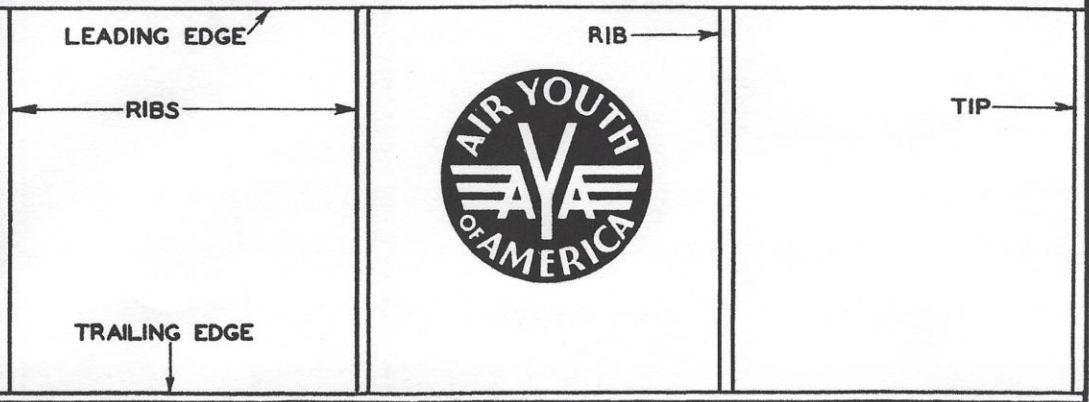

**CONSTRUCT ALL PARTS OVER PLAN**

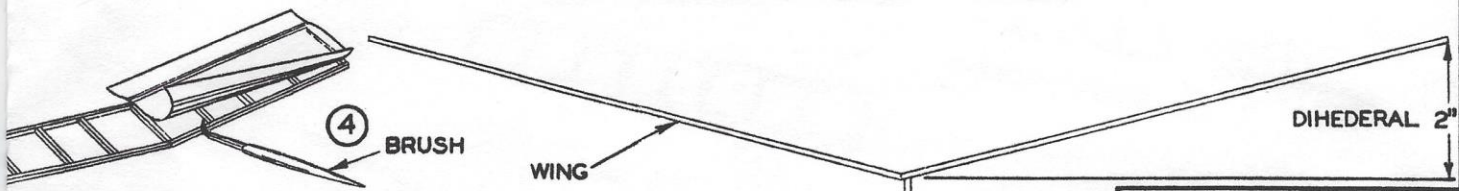

APPLY PAPER COVERING WITH BANANA

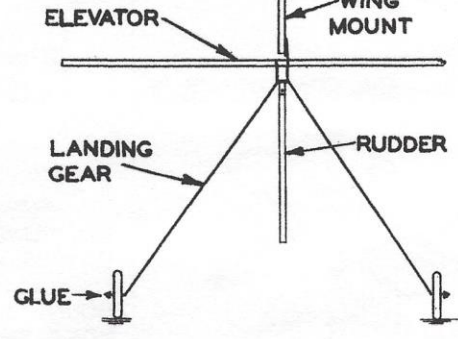
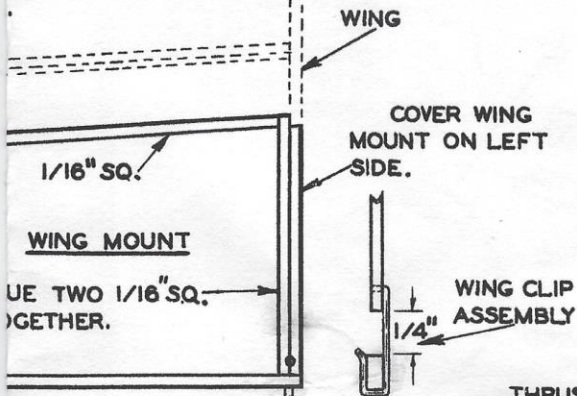

**FLYING INSTRUCTIONS**

Assemble entire model and glide it to check the balance. Move wing backward if model stalls and forward if it dives.

Now wind the propeller about 50 turns. Release model and propeller at the same time. Model should fly on an even keel and then slowly glide to the ground.

Keep increasing the number of winds until the model climbs and circles to the left.

The rubber may now be fully wound. Place model on the floor and allow it to R.O.G.: Rise Off Ground.

**FINISHED MODEL**

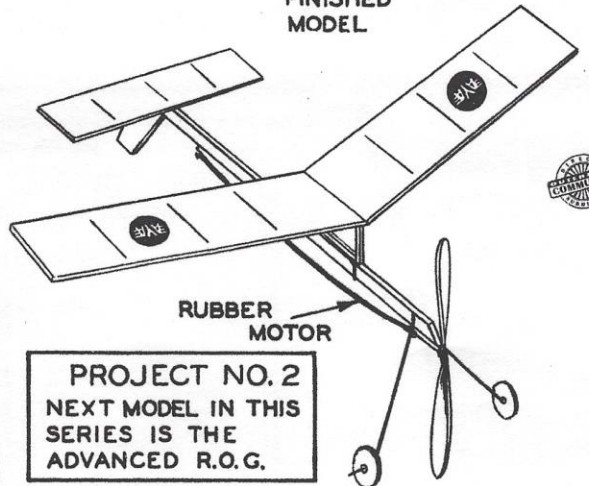

**PROJECT NO. 2**  
 NEXT MODEL IN THIS SERIES IS THE ADVANCED R.O.G.

THE DESIGN OF THIS BABY R.O.G. HAS BEEN APPROVED BY THE AIR YOUTH OF AMERICA.

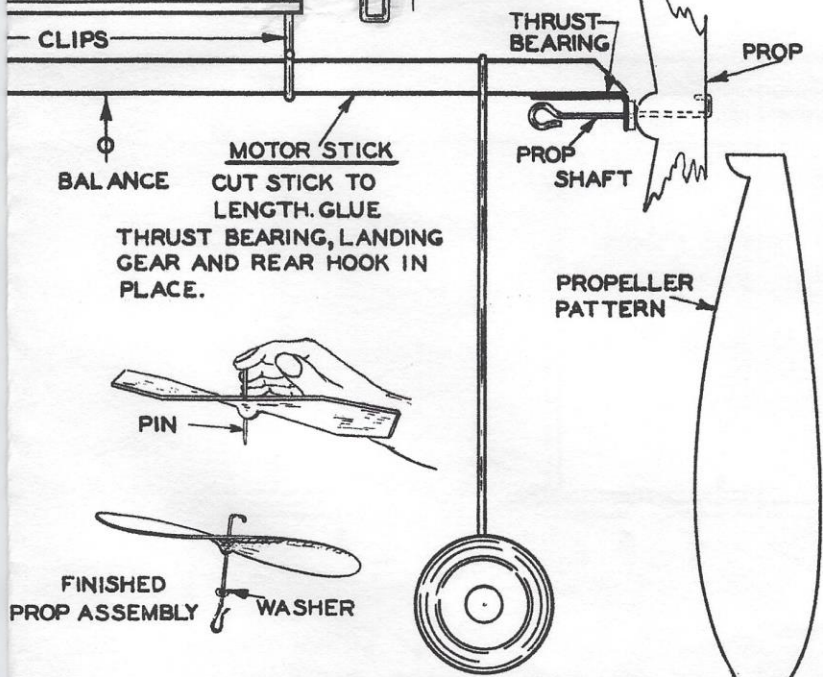

**MOTOR STICK**  
 CUT STICK TO LENGTH. GLUE THRUST BEARING, LANDING GEAR AND REAR HOOK IN PLACE.

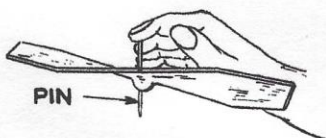

**FINISHED PROP ASSEMBLY**  
 WASHER



**BABY R.O.G.**

SPAN 16"	LENGTH 12"
KIT NO. AYA 2	DRAWN BY SIO. AXELROD

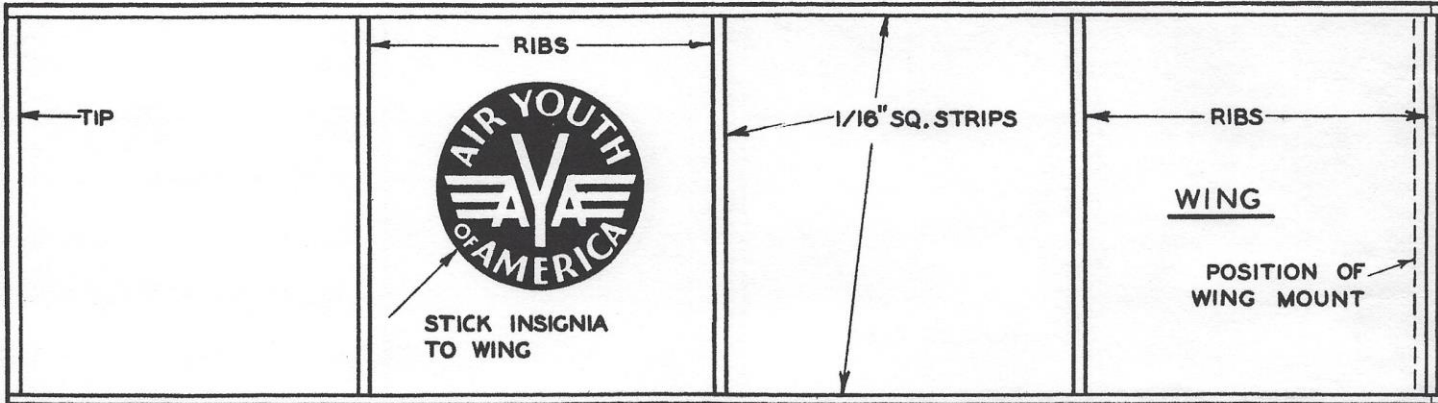

WING CONSTRUCTION STEPS

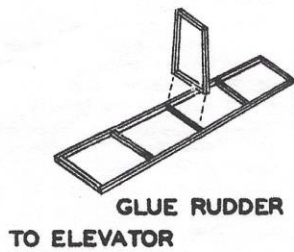
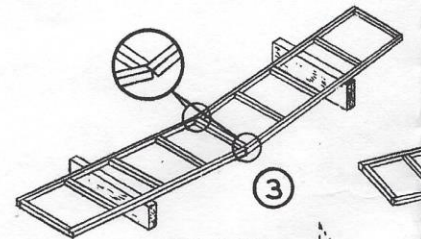
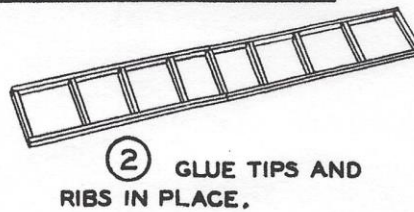
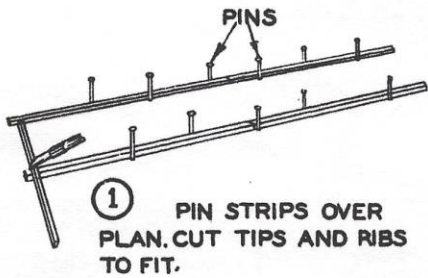

TAIL CONSTRUCTION

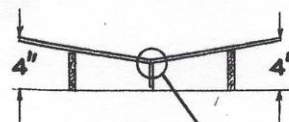
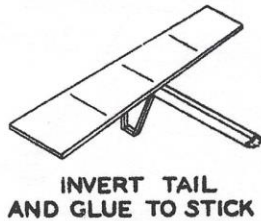

BUILD, COVER, AND GLUE CLIPS TO WING MOUNT THEN GLUE WING MOUNT TO WING. NOTE THAT MOUNT IS GLUED TO LEFT SIDE OF RIB.

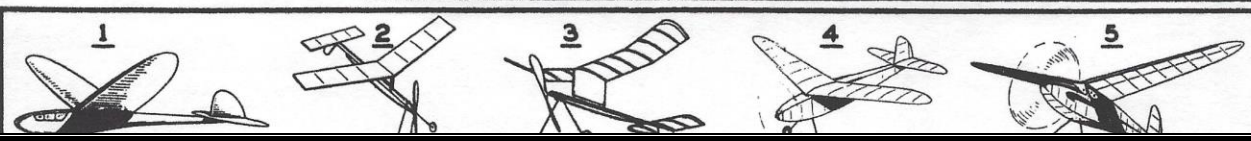
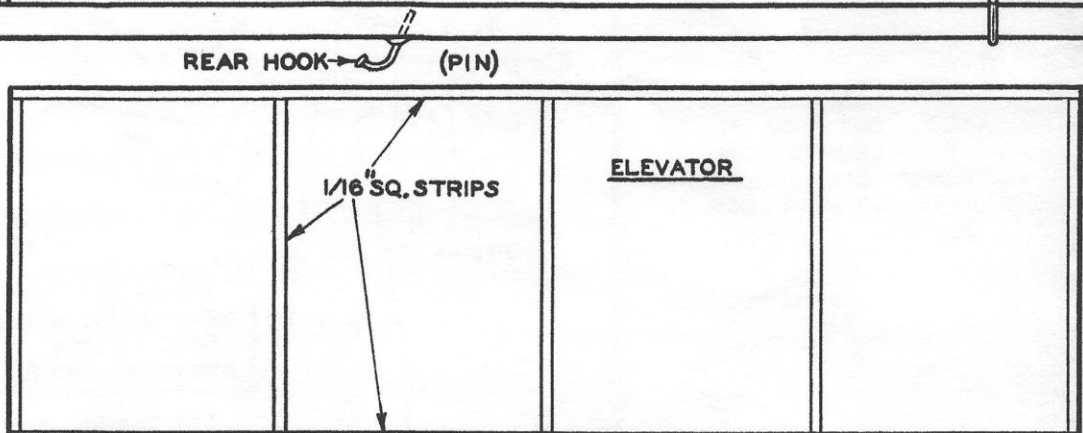
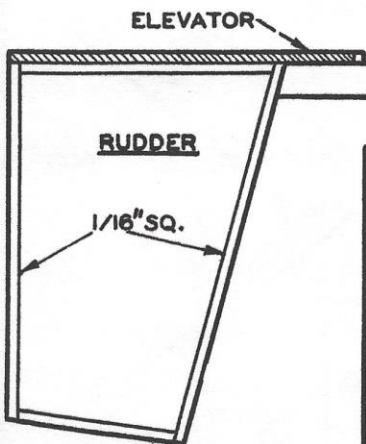
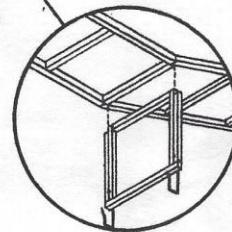

AYA-1 GLIDER      AYA-2 BABY R.O.G.      AYA-3 ADVANCED R.O.G.      AYA-4 FUSELAGE MODEL      AYA-5 OUTDOOR MODEL