

EL TORBELLINO

NEWSLETTER OF SAN DIEGO ORBITEERS FREE FLIGHT CLUB

OCTOBER 2009



PREDISIDENTS COLUMN - M.Pykelnv

San Diego Orbiteers sponsor two contests a year. We already have had our Dual Club Annual and now it's time for the **Southwest FAI Championship**, October 24 & 25, 2009. Bill Booth Jr. and Bob Beecroft run this event for us.

Being in Boulder City , Nevada what a great opportunity for a getaway weekend. Fly during the day and partake in Las Vegas' attractions at night. An added benefit is that this is an America's Cup Point Event.

Support your clubs events.

Orbiters- You developed P-30. Now it's time to build a winning design to compete in the Southwest Regionals International P-30 Challenge; being held in Eloy, AZ. January 17, 2010.

Larry Bagalini has the Pzaz, Perky 30, Pirate, and Air Shark MK2 available as kits and NARF's. Also Larry has the RED props we need. Remember only RED or YELLOW plastic Check props.

MONEY MATTERS - H.Haupt

Starting Balance (09/01/09) \$1,603.24

Income:

Dues (1)	25.00

	\$ 25.00

Expenses:

September Newsletter	12.64
BofA Account Fees	3.00
Pizza Under Payment	2.00

	\$ 17.64

Ending Balance (09/30/09) \$1,610.60

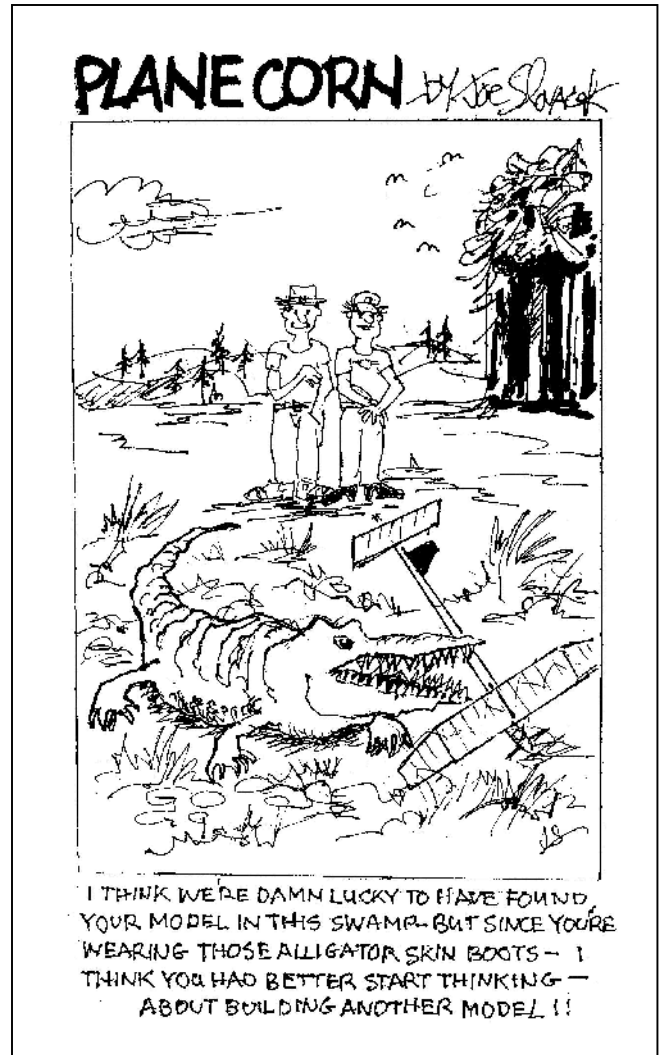

2009 ORBITEER FLYING SCHEDULE

- Oct 18 - P-30
Oct 24/25 SW FAI Challenge*, Boulder City NV
Oct 25 - Scale Staffel FAC Scale Contest* (3 or 3)
Nov 15 - Old Timer, P-20 & HL/Cat Glider
Dec 20 - Coupe (Festival)

2009 ORBITEER SCHEDULE

- Oct 1 - Scale Staffel Hanger Flying at San Carlos
Oct 4 - Indoor flying at Grossmont College
Oct 9 - Orbiteer Monthly Meeting at Scripps Ranch
Oct 16 - Scale Staffel Indoor Flying at San Carlos
Oct 18 - Orbiteer Monthly (**P-30**) at Otay Mesa
Oct 24/25 SW FAI Challenge*, Boulder City NV
Oct 25 - Scale Staffel FAC Scale Contest* (3 or 3)
Nov 1 - Indoor flying at Grossmont College
Nov 5 - Scale Staffel Hanger Flying at San Carlos
Nov 13 - Orbiteer Monthly Meeting at Scripps Ranch
Nov 15 - Orbiteer Monthly (**Old Timer, P-20 & HL/Cat Glider**) at Otay Mesa
Nov 20 - Scale Staffel Indoor Flying at San Carlos
Dec 3 - Scale Staffel Hanger Flying at San Carlos
Dec 6 - Indoor flying at Grossmont College
Dec 13 - Orbiteer Monthly Meeting at Scripps Ranch
Dec 18 - Scale Staffel Indoor Flying at San Carlos
Dec 20 - Orbiteer Monthly (**Coupe (Festival)**) at Otay Mesa

* Non-Club Points Event

Otay Field Weather (619) 661-8297

Orbiteer monthly meetings held the 2ND Friday of each month,
@ Scripps' Ranch, 11885 Cypress Canyon Road,
with the meetings starting at 7:00 PM.

Orbiteer monthly outdoor contests are held on dates shown,
@ Otay Mesa flying field, starting at 8:00 A.M.

Grossmont College monthly indoor flying held the 1ST Sunday of each month, @ Grossmont College in the gymnastics gym, starting at 9:00 A.M.

Scale Staffel events are the 1ST Thursday at 7:30 PM, and the 3RD Friday at 6:45 PM, of each month at the San Carlos Recreation Center, 6445 Lake Badin Ave.

2009 OFFICERS

President
Mike Pykelny (858) 748-6235
Vice President
Larry Miller (858) 292-1434
Secretary
John Merrill..... (619) 449-4047
Treasurer
Fudo Takagi (619) 234-0074
Safety Officer & Field Marshall
Don Bartick (760) 789-3773
Competition Director
Larry Miller (858) 292-1434
El Torbellino Editor
Howard Haupt (858) 272-5656

MEMBER EMAIL ADDRESS'S

Alling johnsair@aol.com
Arroyo garroyo@asymtek.com
Bagalini starlink flitetech@yahoo.com
Banks flylong@cox.net
Bartick dbartick@4-warddesign.com
Beecroft bob@theaerosmith.com
Booth booth@boothsuarez.com
Castillo delcas45@aol.com
Chomyn chomyn@roadrunner.com
Haupt hlhaupt1033@att.net
Hobbs sidhobbs@cox.com
Hutchison johnhutchison1@cox.net
Ives dives@bendbroadband.com
Joseph pljoseph@sbcglobal.net
Keck kandwfmfg@aol.com
Langdon rlangdon289@cox.net
Love plove@san.rr.com
Mansfield george_jr@sbcglobal.net
Martin martin1800@gmail.com
Merrill johnrmerrill@yahoo.com
Miller lmiller1@ureach.com
Musick musickml@comcast.net
Oldenkamp boxblldr@hotmail.com
Overcash robertovercash@cox.net
Peck-Miller sandyshm@aol.com
Phillips norman_phillips@msn.com
Piserchio piserchi@mail.sdsu.edu
Primbs cprimbs@cox.net
Pykelny mpykelny@dslextre.me.com
Ray ralphray@earthlink.net
Rioridan donaldriordan@msn.com
Roush beroush@charter.net
Saba sa6831@toast.net
Seamster seamster@cox.net
Steinmetz hls7777@cox.net
Sullivan gesullivan5050@sbcglobal.net
Weissenberger kathleen_theobald@yahoo.com
Willis willisasoc@aol.com
Yost cyost42747@aol.com
Zachman zachmancapzac@cox.com

ORBITEERS YEARLY MEMBERSHIP DUES

Junior - \$10 Senior - \$15 Open - \$25
65+ - \$15 Family - \$30 Subc - \$15
Lifetime membership - \$250

Submit dues to club treasurer or editor:

Fudo Takagi (Treasurer) (or) Howard Haupt (Editor)
2168 Newton Ave 3860 Ecochee Ave
San Diego, CA 92113 San Diego, CA 92117

THE FINE PRINT

El Torbellino is the official newsletter of the San Diego Orbiteers, an Academy of Model Aeronautics Charter Club (#1113) and a California not for profit corporation. This newsletter is sent monthly to all paid

members, selected exchange and magazine editors. Non-members may subscribe at \$15.00 per year within the U.S.A., offshore price will be adjusted to reflect the postage incurred. Materials from El Torbellino may be reproduced on an unlimited basis by other publications, but proper credit is requested.

ORBITEER WEB SITE
www.SanDiegoOrbiteers.com

OCTOBER IS FOR SHARING YOUR HINTS, TIPS and TRCKS - L.Miller

After our Oct. 9th business meeting there will be a **Big Show and Tell** session which promises to be interesting, informative and helpful to all members. This sharing program is calling on your experience and definitely needs your input and participation.

I am asking all of you to bring in 4 to 7 **or more** of your favorite building / flying hints, tricks, and shortcuts. We are looking for ideas about: techniques, alternate methods, easiest way, best practices, different approaches, how and how not to as in mistakes learned and how solved, and best and worst products used, handy tools made and helpful jigs and templates. Sometimes tips simplify a process to make a process easier, faster, cheaper, and safer. Tell your friends what these tips are.

We want to hear from you! Your ideas and tips do not have to be new, original or developed by you. Most ideas are derivations of previous ideas. All ideas are good and all are wanted and needed for this sharing program. Bring in a model and show how something was built or repaired. Show how a carbon strip was used or new prop was carved or hinged. Look around your workshop for a process you had trouble with, but got resolved with a brain flash, by talking with others, read about it or saw a diagram of how to fix it in a magazine. What product did you borrow from your spouse that you now keep in the workshop? You may even want to bring in a problem and ask the club for suggestions or find out how and why it works or should work. Your participation and support will help make this program worthwhile for everyone.

Thank you,
Larry M.

SEPT. 2009 MEETING MINUTES - J.Merrill

A lucky 13 in attendance tonight, including: Mike Pykelny, Larry Bagalini, Howard Haupt, Don Bartick, Jerry Sullivan, Harry Steinmetz, Gilbert Arroyo, Bob Overcash, Bob Beecroft, Bill Booth, John Oldenkamp, John Hutchison, and John Merrill.

First my apologies, as I came into the meeting a few minutes late. I entered during a discussion which seemed to be about ways in which to increase our revenues. It became obvious that I had missed most of that discussion, so hopefully someone else can fill in that section. (ED: Mike Pykelny initiated discussion of the seven revenue items tabled at the August monthly meeting. They were briefly discussed and referred to the current revenue committee for further consideration.)

Contest Reports – Bill Booth talked about an FAI America’s Cup contest to be held the last weekend of October. They will also fly P-30. It will be held at the El Dorado Dry Lakebed, near Boulder City. Mike Pykelny mentioned the Southwest Regionals, and the P-30 challenge. Only red or yellow Czech props are to be allowed.

John Hutchison then talked about an upcoming indoor contest on the first Sunday in December at the Grossmont College gym. It will be a “one-design” contest of the “Gymbox”, and it has to ROG, and it should have a 6 inch plastic prop. The Gymbox was designed “many moons ago” by our own John Oldenkamp. Bob Overcash brought along a fine example he has built, and said he has flown his for over one minute so far. (ED: Cash prizes will be offered for 1ST thru 3RD place finishes.)

Old Business – Don Bartick had a question about the sanitary conditions of the Otay field porta-potty. He said he will call to have it serviced. Thank you Don!

Show-and-Tell – John Oldenkamp started out with a P-30 variation of “The Pirate”. Round wood fuselage and a pop off wing. Quarter-mil clear covering on the rudder and stab. The wing had a red and white color scheme, and was a beauty as always. John said it was built during last week’s “Birthday week”, and it all started, or was inspired

by, finding a 4 ½ lb. piece of balsa, which he knew would make a good rolled tube fuselage. Larry Bagalini showed us a beautiful “D Box”, with carbon fiber L.E. and T.E. on the wing and tail, and he calls this plane the “Splenda D”. It was made by Andrey Burdov of Russia, using “all the finest materials”. Contact Larry if you want one, but hurry, he only has 2 at this time, and both are gorgeous. Both qualify for Coupe/F1G. The meeting adjourned at 8:08 p.m., and indoor flying ensued, with a great competition. Respectfully submitted by John R. Merrill, tardy secretary.

ON THE LIGHTER SIDE - H.Haupt

Our September meeting concluded with spirited hanger talk and some friendly indoor flying. Don Bartick experienced some breakage and repairs on his way to his high time. John continues to hand wind and put in very competitive times. Results follow:

H.Haupt	Butterfly	73	seconds
J.Merrill	Butterfly	65	
D.Bartick	Butterfly	59	

Pizza will be available from Venice Pizza House at our meeting this month. Bring your favorite drink, as well as some money to cover your \$2.00 per slice charge for your favorite pizza. Plates, paper towels, plastic utensils, and trash receptacle will be provided.

SEPTEMBER MONTHLY - J.Oldenkamp

Glorious day with decent turnout, spotty thermals early, plus many common gremlins not seen in such numbers of late: Early D/T from great altitude— J.O., not once, but twice; In-flight tailboom fracture, D.Bartick’s TailHigh Coupe; He also dinged his new ½ A Predator on a test flight; L.Miller’s Coupe shed its pylon/wing components while on the way to a max in good lift; L.Bagalini blew three motors at the Round One close for an unforced error and DNF; In the B Electric flyoff, B.Overcash D/T’d with motor running at launch, voiding the attempt. And those were only the ones that were reported, or that our valiant pilots owned up to!

Coupe d’Hiver: 5 x 120s

Bob Overcash	Candy G	512	secs.
J.Oldenkamp	IceBox 41	494	
Mike Pykelny	Candy G	423	
Larry Miller	Mod. Candy G	330	
Harry Steinmetz	Mod. Candy G	248	
Don Bartick	HighTail	218	
Marh Chomyn	Slats	30	

Power, All Classes: 3 x 120s

John Oldenkamp	JouleBox	406
Bob Overcash	ePearl 270	360
Mike Pykelny	Marval 270	325

CD: J.Oldenkamp

ART WAY SILENT AUCTION - H.Haupt

A silent auction will start this month for the model airplane supplies donated to the club by Ronnie Way on behalf of former member, Art Way. Proceeds from the auction will be benefit both the club and Ronnie Way.

This auction will run for several months with the current high bids published in the newsletter and distributed by special email as needed. When current bids are published, and you find you have been out bid on an item of interest, then please feel free to submit a higher bid to secure the item for yourself.

If you wish to bid on any of the items, you can submit your bids by phone, email, or U.S. Mail. Submit your bids to:

- Phone - (858) 272-5656
- Email - hlhaupt1033@att.net
- Mail - Howard L. Haupt
3860 Ecochee Ave.
San Diego, CA 92117-4622

At the close of the auction, the highest bidder on each item has the right to cancel the purchase, if upon inspection the item does not meet expectations.

Look for the “Art Way Auction List” in this issue of the El Torbellino. (ED: Follows on next page.)

ART WAY AUCTION LIST

(Where to bid shown at end of list)

Comet Kit: Fohker D VII (12")
Ryan SC (12")
P51 Mustang (18")
Stinson SR-7 (25") (2 kits)
DeHavilland DH-4 (22")
F6F Hellcat (24") As is with Formers/Other parts cut out
P47 Thunderbolt (24")
Curtiss Robin (22")
Piper Cub J-3 (25 ½") As is with Ribs/Other parts cut out

Easy Built Models: Miss Canada Jr. (25")
Taylor Cub (12")

Guillows: Hal Krier's Great Lakes Special (24")
Aeronca Champion 85 (24")
Japanese Zero (27 ¾")

Sterling Models: Waco S.R.E. Interstate Cadet (12"0) As is with some work started

Keil Kraft: Ercoupe (20")
Fokker D-8 (16") As is with parts cut and fuselage sides glued

Peck Polymers: Druine Turbulent (12")
Piper J32 Cub (12")

Scale Model Co.: Harlow (16")

Tern Aero Co. Inc.: Ryan ST (17")

Midwest: Sniffer (26 ½") As is with some parts cut out

Carl Goldberg: Cessna Skylane (42") RC or FF uses .049 engine

Sig: Ramrod 250 ½ A
Wonder RC Sport Model (37 ½")

Tyco Models "Bay Ridge Mike" (48 ½") As is with Ribs/ Wing Tips cut out, no covering material or hardware
Wind Free RC Soaring plane (99")

SUPPORT EQUIPMENT

Orbiteer Golf Shirts (new), (1) Red XL, (1) Blue L

Anti-Sticker Leggings, Nylon with side zipper (new)

Zaic Yearbooks 1935-36, 1937, 1938, 1955-56 (Bid for individual books or the whole set)

Model Aeronautics Made Painless by R.Hoffman

Outdoor Winder (Merrell) with aluminum frame (3 ½ : 1 ratio)

41 - Falcon

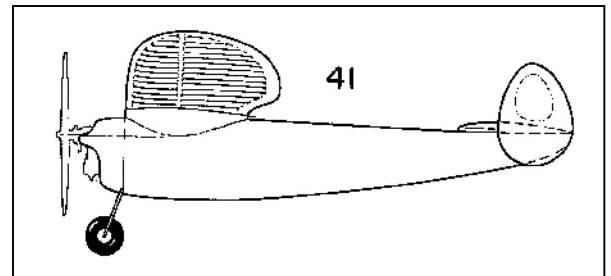

Antique hand drill winder for outdoor winding

Plastic tow- line reel

Hand held Gas Motor Starter, Uses 12V as energy source

Covering iron

A Bag of Mechanical Timers

Tatone D-T Tick Off timer (Clockwork) in box

Tatone "74" Timer (Clockwork), marked for use on 1/2 A

Texas Micro I Timer in box

Mechanika Teplice Time (Clockwork) marked for use on F1A, in box

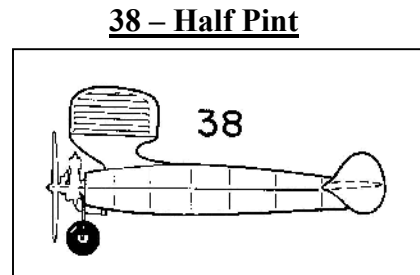

Indoor winder (Round metal type) (16 : 1 ratio)

Indoor winder (Small round plastic type (Kyosho)) (5 : 1 ratio)

One Pound box of Tan II rubber 1/8"

Peck Polymers Bag#1

Pack of 6 large button bearings (white), Pack of 3 pair 1" wheels, 4 1/2" propeller

Peck Polymers Bag#2

Pack of 6 small button bearings (white), Pack of 3 pair 3/4" wheels, 4 1/2" propeller

Peck Polymers Bag#3

Pack of 6 small button bearings (black), Pack of 3 pair 3/4" wheels, 4 1/2" propeller

Master Airscrew Balsa Stripper (2 available)

Master Airscrew Balsa Planner

Box of Engine Mounts

Tatone 15, 15/1, 29; Large and small Nylon; Plus some miscl ones

Box of Outdoor Wheels

Pairs of DuBro 3", Veco 2 1/2", DuBro 1 3/4", Perfect 1 1/2", Veco 2", miscl wood wheels

Box of Plastic Props

Square tip: (2) 3 1/2", (4) 4", (6) 5 1/2", (2) 7"; Square tip wide blades: (1) 5", (2) 6", (1) 7"

Round tip: (3) 3 3/4", (1) 5", (1) 6", (5) 9 1/2"

(A total of **28** plastic props)

Box of Balsa, Wood, and Nylon Props

Balsa Props: (2) 7" Bladed folder, (3) 8" carved, (2) 9" One bladed folder, Miscl blades

Wood Props: (2) 10", (4) 12", (1) 14"

Nylon Props: (1) 4 1/2", (1) 6", (1) 9"

(A total of **17** props)

Acculab Model 2001 Digital Scale, Capacity: 2000g/70oz, Graduation: 1g/0.1oz

Hand held (pocket size) mechanical postage scale

Radio Shack AC/DC Volt-Meter

PF-12 Park Flyer AC/DC Peak Charger for NI-MH and NI-CD batteries (4 to 12 cells)
250 ma to 2000 ma, power source is 110V & 7 cell 650 ma battery pack included (new in package)

Hitec Multi Charge-A-Matic, 270ma to 1800ma @ .9 – 4.5amps for 4.8 to 12 volts,
Power source is external 12v battery. Trickle charge of 50ma to 200ma

Craftsman Scroll saw with 15" throat

Field Box / Stool with storage under seat with lift out tray, pre-stocked with this and that

Field Box (Fishing box style), with 3 trays, pre-stocked with this and that

Metal tool caddie with carrying handle stocked with the following tools:

Allen wrenches, Small hand drill, (5) 1" C-clamps, 12" Crescent wrench, 6" Adjustable wrench (Allen), 6" chisel, Center punch, 19mm Box wrench, Paint scrapper, Min-Wax Poly-crylic Clear Satin ½ Pt., Testors Spray Paint - Silver (New), Mini Screw driver set.

Balsa Wood Bundles

- (10) Balsa Sheets (4" x 27") 1/8"
- (10) Balsa Sheets (4" x 27") 1/8"
- (13) Balsa Sheets (4" x 27") 3/32"
- (18) Balsa Sheets (3" x 27") 1/8"
- (5) Balsa Sheets (3" x 37") 1/8"
- (10) Balsa Sheets (3" x 37") 1/16"
- (5) Balsa Sheets (3" x 37") 1/32"

Bundle of small balsa sticks

Bundle of large balsa sticks

37- GUFF

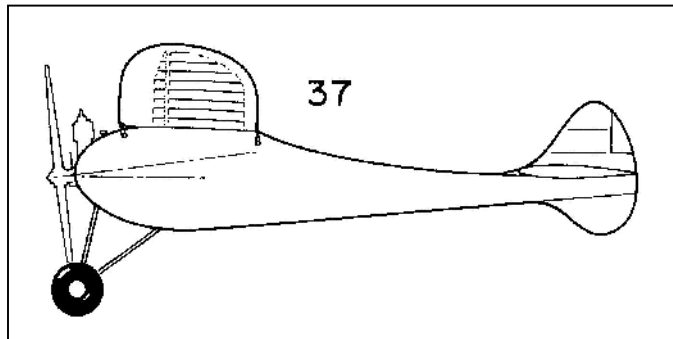

Free Stuff

Don't be shy, they are free, but if you want to ace out your fellow modeler who thinks he is getting a freebee, then put in a bid on the item of your choice.

Box of Plans, Xerox Copy Paper size box full to the brim - **Free** to the 1ST person to ask

Box of Mylar Covering Materials - **Free** to the 1ST person to ask

Mini Screw driver set (5sets) - **Free** to the 1ST five people to ask

Multi-Function battery lamp/flashlight - **Free** to the 1ST person to ask

ART WAY SILENT AUCTION

Where to Bid (Specify item and bid price)

By Phone - (858) 272-5656

By Email - hlhaupt1033@att.net

By Mail - Howard L. Haupt
3860 Ecochee Ave.
San Diego, CA 92117-4622



US Free Flight Championships Lost Hills, 9/25-27/2009 - D.Bartick

For all you that may be interested, the following is a brief report on the Champs.

Overall this was a wonderful contest. The weather was hot in the afternoon as expected based on weather reports. The temperatures were ~10 degrees above normal for the period. Morning temperatures started at ~65 degrees and by noon in the high 90's. No wind to speak of. Just a slight breeze with periodic calm. A totally flyable contest.

Arline and I went up Thursday. I had volunteered to help construct an ROW pond. The pond materials were donated by the Blacksheep Club. We didn't start building until near sunset as the temperature dropped considerably. With the elaborate instructions and so-so carpenter skills and lots of supervision we got the thing built. I had been carrying around floats for my 1/2A Privy Boy for years waiting for a ROW opportunity. Flying off the pond commenced Friday. What a hoot. There was ROW competition for rubber and power.

A neat feature of the contest was having qualifications on Friday. You could put up the first three flights in all but AMA power, Mulvihill, HLG & CatG events. If you max'd out, you then flew the fly-off on the scheduled day. This sure help spread out the agony of flying lots of events.

Entries were in the high 60's. Ted and Sandra Firster did an excellent job running

the show. Ted came up with a scoring system that provided near instant results for award. Lots of merchandise was accumulated for the drawing. Ted thanked all the clubs and individuals that contributed. Awards this year were 2 sizes of glass mugs along with cash for the Sweepstakes and 3 event championships. A few lucky folks got to lug off the huge perpetual trophies.

As far as yours truly, I flew 4 events. Place first in Mulvihill and 1/2A Nos. Second in P-30. I broke a couple planes along the way. Oh-I forgot to mention my ROW adventure. I could get off the water, but couldn't clear the sides. After 4 attempts I thought it best to preserve the Privy Boy for winning the 1/2A Nos event. Good choice. Tom Carmen won the gas ROW event. He advised me that my front float needed more incidence. I'll try again next year.

Orbiteers—you missed a great contest.

Don Bartick

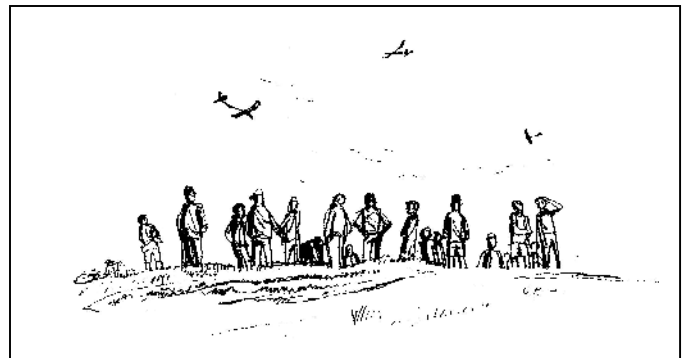

SOUTHWEST FAI CHALLENGE

OCTOBER 24 & 25, 2009

BOULDER CITY, NEVADA

SPONSORED BY THE SAN DIEGO ORBITEERS
AN AMERICAS CUP EVENT

CONTINUATION OF THIS EVENT WAS MADE POSSIBLE BY THE ENTHUSIASTIC EFFORTS OF JILL ROWLAND-LAGAN, CEO OF THE BOULDER CITY CHAMBER OF COMMERCE. PLEASE PATRONIZE BOULDER CITY MOTELS, RESTAURANTS AND BUSINESSES AND TELL THEM WHY YOU ARE THERE.

For Classes: F1A, F1B, F1C, F1G, F1H, F1J, F1P, F1Q, P-30 and Vintage FAI Power

Saturday October 24th: F1A, F1B, F1C, F1P, F1Q and Vintage FAI Power

(7) One hour rounds commencing at 8:00AM for all events except Vintage FAI Power which will only have (5) rounds beginning at 9:00AM

Round 1: F1A, 210 Seconds, F1B and F1C, 240 Seconds, Rounds 2-7: 180 Seconds

F1P, 180 Seconds, All Rounds

F1Q, 15 Second Motor Run, 180 Second Max, All Rounds. F1Q Flyoffs will use decreasing motor runs, 180 Second Maxes

Vintage FAI Power, 180 Seconds, All Rounds. Vintage FAI Flyoffs will use same engine runs, Extended Maxes

Saturday Fly Offs will begin at 4:30PM (weather permitting)

Sunday October 25th: F1G, F1H, F1J, and P-30

Tie-Breaker "Espresso Fly-Off"(No Max): F1G 7:30-7:40; F1H 7:45-7:55; F1J 8:00-8:10

(5) 45 Minute rounds commencing at 8:30AM

All Rounds: 120 Seconds

P-30 8:00AM to 12:00PM, No Rounds

Sunday Mini-Event Flyoffs

No later than 12:30PM (45 minutes after close of Round 5), any required flyoffs will begin. The first flyoff round Max will be 180 seconds for all events. The second flyoff Max, if required, will be 240 seconds. The third flyoff Max, if required, will be 300 seconds. If a winner is not determined at the conclusion of these three flyoff rounds, the Espresso Flyoff times will be used to determine final placing.

There will be NO timers provided. Please find someone to fly and time with you.

Awards

Perpetual Trophies to winners in F1A, F1B, F1C, F1G, F1H and F1J

Glassware 1st through 3rd place for all events, including F1P, F1Q, Vintage FAI Power, P-30 and winners of Espresso Flyoffs

Entry Fee: \$30 for first F1 event entry, \$10 for each additional F1 event entry

P-30 \$10, no entry fee for Juniors or Espresso Flyoff

Contest Director:

Bill Booth Jr.

5092 Nighthawk Way

Oceanside, CA 92056

(760) 842-1079

booth@boothsuarez.com

Bob Beecroft

3488 Linda Vista Terrace

Fallbrook, CA 92028

(760) 723-2499

TheAeroSmith@roadrunner.com

Directions to El Dorado Dry Lake:

On Hwy 95 approximately 7 miles south of Hwy 93. Access through the Desert Tortoise fence is on the west side of Highway 95 on the north edge of where the power lines cross the highway. The flying area is to the west, approximately in the middle of the lake bed. In the early morning, the field is approximately 35 minutes drive time from the Las Vegas "Strip". Camping on the field is permitted.

SAN DIEGO ORBITEERS

Howard Haupt / Editor
3860 Ecochee Avenue
San Diego, CA 92117-4622



WHAT'S HAPPENING

OCTOBER 2009

- Oct 1 - Scale Staffel meeting for Hanger Flying, San Carlos, 7:30 pm.
- Oct 4 - Indoor Flying, Grossmont College, 9:00 to 12:00 pm.
- Oct 9 - **Orbiteer Monthly meeting at S.D. City Serv. Cntr. @ Scripp's Ranch,**
11885 Cypress Canyon Road, Meeting starts at 7:00 pm.
Indoor Fun Fly featuring A-6 & Gliders up to 8" follows the meeting.
- Oct 16 - Scale Staffel Indoor Fun Fly, San Carlos Rec. Cntr., 6:45 pm.
- Oct 18 - **Orbiteers Monthly, Otay Mesa, 8:00 am.**
Non-power: **P-30** Power: **All Classes**
- Oct 24/25 Southwest FAI Challenge, Boulder City NV, See enclosed contest flyer.
- Oct 25 - Scale Staffel FAC Scale Contest (3 of 3), Otay Mesa, 7:00 AM.

Local Field Weather: (619) 661-8297
