

"EL

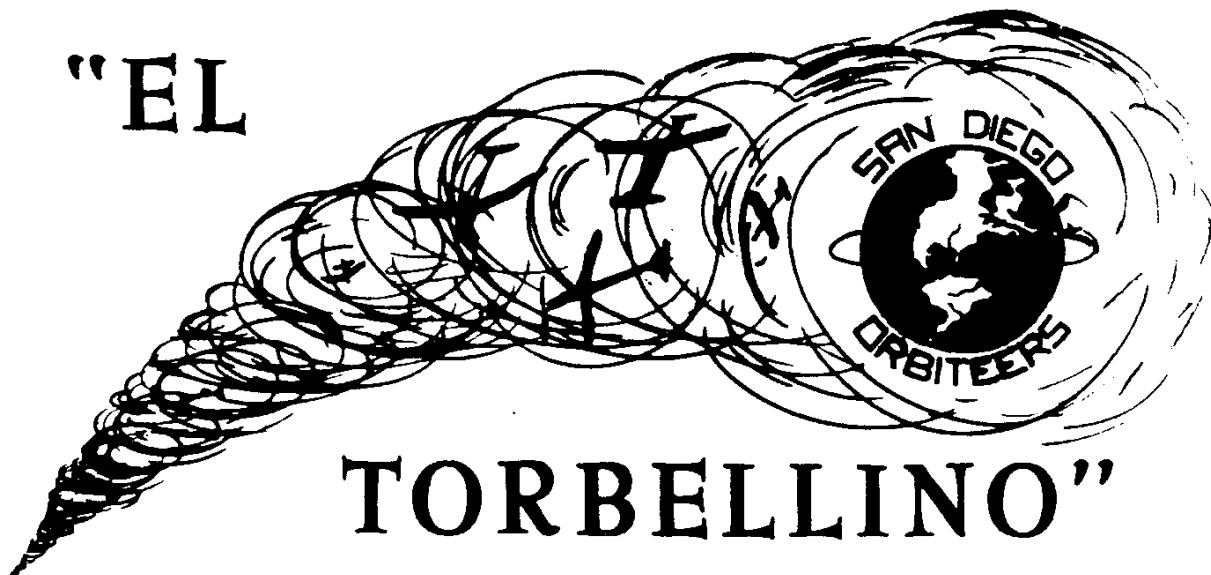

TORBELLINO"

MAY 2013

The Prez's Corner – Don Bartick

A week from now as I write this column, Arline and I will be on our way to Lost Hills to set up for the 55th Orbiteer Annual along with the Fresno Gas Model Club's 75th Annual. This makes up the popular Dual-clubs FF Bonanza. The plaques are in the mail, ice cream is ordered for the Saturday noon time ice cream social and folks are preparing side dishes for the Saturday evening potluck. Oh, there will be flying going on also. The long term weather forecast looks favorable for great weekend. I hope to see a few more Orbiteers there then years past.

We were all saddened by the passing of Orbiteers Cezar Banks and Fudo Takagi. Both were very well known to the world of Free Flight. More will be said about them by Howard.

We had a wonderful time at the San Valeers Annual. The venue was also shared by the SCAMPS and SCIFS contest. Participation was less then hoped for, but the competition was keen. The weather was outstanding.

Taking about contests, we went to WESTPAC IV Scale contest at Perris. It was my very first scale FF competition and the first time on the SCAMPS Perris field. As mentioned last

month, I had planned to finish my P-38 and compete. Well I did finish the plane at 12:30am the night before we left. Wednesday was judging and the flying started Thursday morning. Arline was the official photographer. The weather was spectacular all days of the event. Unfortunately, the first test flight of the P-38 was a disaster. There was no tall grass on the field or nearby and I went ahead and tried to fly anyway. Did an overhead and crashed. The plane wasn't repairable to continue. I became a spectator the next 3 days. Regardless, I really enjoyed watching the competition and plan to participate in scale FF from here on out. Roger Willis organized a great meet. John Hutchison along with Kathy directed the contest superbly.

The second of the indoor rotations was held Sunday, May 4th. Phantom Flash was contested with 10 entries. Serious competition. Look in the ET for results.

This is a wrap for now.

Remember; today is the tomorrow you worried about yesterday.

2013 ORBITEER FLYING SCHEDULE

May 18/19 Dual Club FF Bonanza, Lost Hills CA

May Rotation Skipped: (Nos. Rubber)

June 9 - Coupe, Power, & Glider

June 16 - SCAMPS Contest*, Perris CA

July 4 - Walt Mooney Annual Scale Contest

July 21 - P-30, Power, & Glider

Aug 18 - Nos. Rubber, Power, & Glider

Aug 5 - Scale Staffel FAC Contest* (1st of 2)

Sept 15 - Coupe, Power, & Glider

Sept 20-22 US FF Championships, Lost Hills

Oct 20 - P-30, Power, & Glider

Oct 26-27 SW FAI Champs*, Boulder City, NV

Oct 27 - Scale Staffel FAC Contest* (2nd of 2)

Nov 17 - Nos. Rubber, Power, & Glider

Dec 15 - Coupe, Power, & Glider

* Non-Club Points Event

Otay Field Weather (619) 661-8297

MONEY MATTERS - H.Haupt

04/12/13 thru 05/13/13

Income:

Dues (3) 55.00

Expenses:

Apr. Newsletter 4.92

Spank's 65.00

Celtic Tides (Awards) 708.00

Current Balance \$ 456.78



BOARD OF TRUSTEES

President / Chairman

Don Bartick (760) 789-3773

dbartick@4-warddesign.com

Vice President / Chairman

Larry Miller (858) 292-1434

miller1@ureach.com

Secretary

John Merrill (619) 449-4047

johnmerrill@yahoo.com

Treasurer

Howard Haupt (858) 272-5656

hlhaupt1033@att.net

Fudo Takagi "Treasurer Emeritus"

Trustees at Large

Mark Chomyn (760) 753-7164

chomyn@roadrunner.com

John Hutchison (619) 303-0785

johnhutchison1@cox.net

Mike Pykelny (858) 748-6235

MPykelny@dslextreme.com

ORBITEER TASK LEADERS

Safety Officer & Field Marshall

John Oldenkamp (619) 233-4837

boxbldr@hotmail.com

Competition Director

Larry Miller (858) 292-1434

miller1@ureach.com

Web Master & Yahoo Coordinator

Bob Beecroft (760) 723-2499

bob@theaerosmith.com

El Torbellino Editor

Howard Haupt (858) 272-5656

hlhaupt1033.@att.net

ORBITEERS'S at WESTFAC IV



P-38 by Don Bartick



Yak-3 by Roger Willis



Fokker D-VII by John Hutchison



P-51B by John Merrill

Additional information: With a Malcolm Hood canopy, named Pretty Ann. The original name on the plane in WW II was Patti Ann, but since my wife's name is Ann, I decided to change a few letters ... call it poetic license. (And maybe a few scale points on proof of scale ED.)



Stinson 108 Voyager by Roger Willis

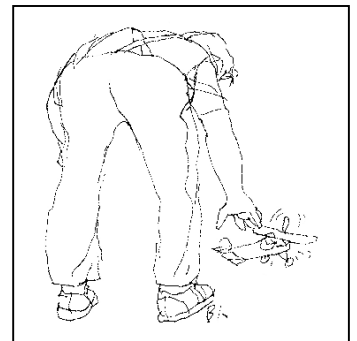

Fudo Takagi (1921 - 2013) - H.Haupt

At the age of 92, Fudo has taken his last big thermal ride into the sky. Fudo hailed from Chicago, and was active with the Chicago Aeronauts, flying free flight models. Some of those early flying years included riding the street car to the end of the line, and flying in the grass covered fields with only a few farm houses in site.

As a young adult, Fudo worked in the Chicago area before coming to the San Diego. I suspect work in the aero space industry is what lured him to our area. His career as a machinist, served him well, while pursuing his hobby interests.

I first met Fudo at the Madison High School gym, where I was flying my first indoor plane, an EZB that was built after school with the guidance of Clarence Mather, as a school club activity. Fudo was flying EZB as well, for it was a new and up and coming indoor class, at the time.

From that first meeting, Fudo was always in my sphere of model airplane activity.

A review of the club history, via the El Torbellino, I find Fudo was a member of the club in 1966, when he was elected Treasurer. He held that post until a few years back, when the money minder duties were passed to me.

Fudo submitted the original El Torbellino mast head design which was actively used until 1974. This is the mast head that has been used for this issue. As a columnist, Fudo wrote a monthly column called 'In & Out', where non-mainstream free flight activities were talked about. His A-6 design was first published in September 1974, with models of that design still being flown today.

As a master machinist Fudo was well skilled in detail work, with this trait carrying over into all his pursuits. All his construction projects were done to perfection, be it Free Flight & Scale Models (indoor & outdoor), creating

mechanical gadgets such as (timers, winders, torque meters, scales) or trophies, you name it he could build it. Although the bulk of his photography work preceded me knowing him, I have been told his work in the field was well regarded with his pictures being published in all the model airplane magazines of the time.

A visit to Fudo's garage and work shop was an eye opening experience. The first impression was that of a space so packed with boxes, that only a narrow path leads the way to the work bench. It too was covered in a layer of tools, projects in process, and materials of model airplane building. It did not seem possible for Fudo to produce such well constructed Free Flight models in such a constrained space with no visible flat area to actually work. But, for Fudo, this work space was the genius of his productivity as a model builder. No need to understand how the space works, just look at the results in the air. I would be a miss to not mention the concise way Fudo employed the use of the English language. The classic example would be the verbal treasurer's reports at the monthly meetings. These reports would be recorded in the meeting minutes as: "We are OK", "The account is low", "It is normal", or "We not so good".

Roger Willis shared the following Fudo story: I was just learning to fly. Fudo was flying next to me at Otay Mesa when my new FAC Moth got into its first thermal. I was amazed and shouting "LOOK LOOK ... Fudo", without missing beat he looked at me and said.... "hay, in a thermal you can fly a 2 x 4". I will never forget that and have told it to all my new builders in building classes in Arizona.

So long my old friend, with the march of time we will catch up with you, on are own last big thermal in the sky,



FROM THE WORKSHOP



Phantom Flash by John Merrill
(From a short-kit sold by Lee Campbell at the recent WestFac contest)

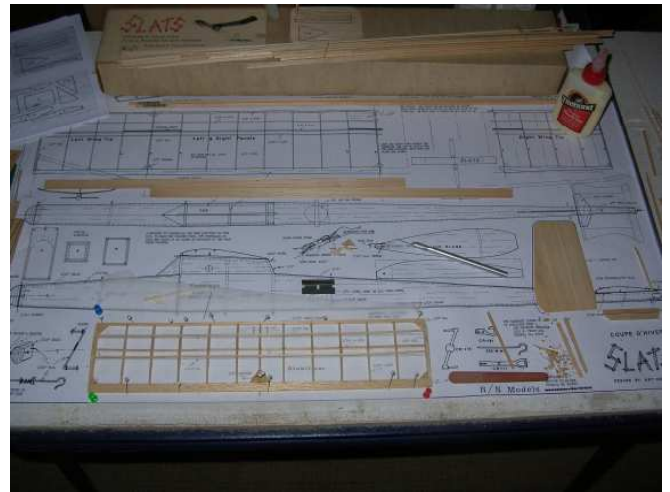

Coupe, "Slats" R/N kit by John Merrill
(Photo 1)

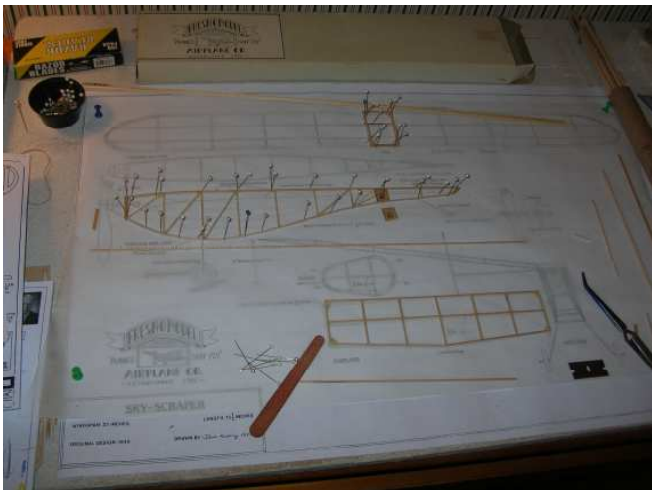

Sky Scrapper by John Merrill (Photo 1)



Coupe by John Merrill (Photo 2)



Sky Scrapper by John Merrill (Photo 2)
1940's design, from Fresno Model Airplane
Co. kit. Also includes plans/parts for a Fury.

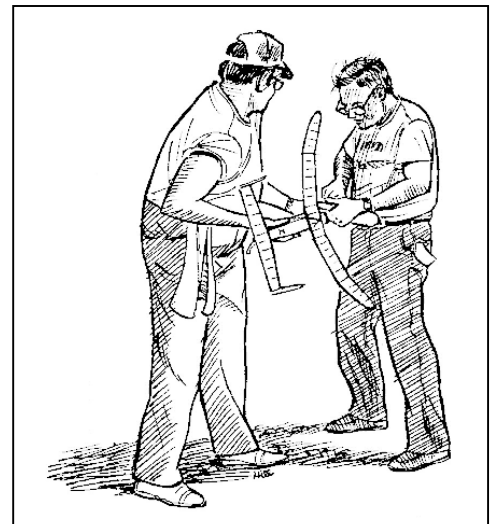

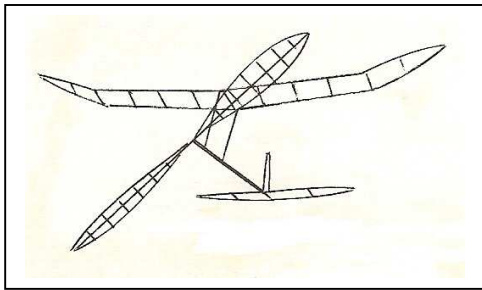

Cezar Banks (1926 - 2013) - H.Haupt

The Orbiteers' resident indoor expert has left the hall. For those of you who flew indoor with Cezar, you are bound to have memories of his presence. Born and raised in Kenosha Wisconsin, Cezar spent the bulk of his working career working as an Electrical Engineer at General Dynamics Convair.

My first meeting with Cezar was at Otay Mesa, where he came to the field with Clarence Mather, and was introduced as a free flight modeler coming back into the fold after an absence of a number of years. His goal at the time was to get back into indoor free flight. This being 1978, Cezar became part of my indoor flying life from that point forward.

From the get go, Cezar had his sights set on indoor micro film planes, and competing in the F1D class. Along the way, he and Clarence became F1D confidants, with both gaining from each others experiences. I viewed Cezar's efforts as very successful, in qualifying for a number of F1D US Teams and competing on the world stage against the best the world has to offer. Winning the individual world title did elude him, but he did finish 2ND on the world stage a number of times.

Indoor Penny Plane flying was maturing when Cezar picked up the indoor bug, and shifting to a sub-class called Novice Penny Plane. Cezar put together a Novice PP design that was a world beater, and was build & flown successfully by hundreds of individuals over time. Another design for an indoor torque meter was quite elegant.

With the passage of time, I shared many trips with Cezar to various indoor venues. Our time together, looking back, seems to of passed much too quickly. I can still hear his booming voice providing trimming advice while flying indoor.

ORBITEERS YEARLY MEMBERSHIP DUES

Junior	- \$10
Senior	- \$15
Open	- \$25
Family	- \$30
65+	- \$15
Lifetime	- \$250
Non-Member Newsletter Subscription	- \$15

Submit Dues to Club Treasurer:

Howard Haupt
3860 Ecochee Avenue
San Diego, CA 92117-4622

THE FINE PRINT THE FINE PRINT

El Torbellino is the official newsletter of the San Diego Orbiteers, an Academy of Model Aeronautics (AMA) Charter Club (#1113) and a California not for Profit Corporation. This newsletter is sent monthly to all paid members, selected exchange and magazine editors. Non-Members may subscribe at \$15.00 per year within the U.S.A., offshore price will be adjusted to reflect the postage required. Materials from El Torbellino may be reproduced on an unlimited basis by other publications, but proper credit is requested.

ORBITEER WEB SITE

www.SanDiegoOrbiteers.com

Webmaster: **Bob Becroft**

A NOTE FROM Linda Piazza

It's that time of year again for our spring and summer contests, wonderful weather, and a grilled hot dog. Attend our monthly contest, fly and have fun. Thank you to those of you who have contributed to keep our grill, grilling. Bring a friend. – Linda Piazza

DUAL-CLUBS FREE FLIGHT BONANZA

A National Cup Event

**SAN DIEGO ORBITEERS 56th ANNUAL - CLASS AA, CATEGORY 2
SPONSOR OF AMA, CLASSIC & MINI-FAI EVENTS**

*

**FRESNO GAS MODEL CLUB 75th ANNUAL - CLASS AA, CATEGORY 2
SPONSOR OF NOSTALGIA, TEXACO & OLD TIME EVENTS**

*** MAY 18th & 19th 2013 *
* LOST HILLS, CA ***

<i>SATURDAY ONLY 7 AM – NOON, 1 - 5 PM LUNCH BREAK W/ ICE CREAM SOCIAL</i>	<i>EITHER DAY MUST FINISH EVENT THE SAME DAY</i>	<i>SUNDAY ONLY 7 AM – 3 PM</i>
½ A GAS (1) C/D GAS P-30 (1) VINTAGE FAI POWER CATAPULT GLIDER (1) ½ A TEXACO DAWN P-30 NIGHT GAS (COMBINED)	SMALL OT RUBBER STICK SMALL OT RUBBER CABIN LARGE OT RUBBER STICK LARGE OT RUBBER CABIN ¼ A NOSTALGIA ½ A NOSTALGIA A NOSTALGIA B NOSTALGIA C NOSTALGIA DAKOTA (Time Target) TOM CARMAN MEMORIAL (2)	EARLY ½ A NOS. .020 REPLICA A PYLON B-C PYLON A FUSELAGE B-C FUSELAGE RUB/WAKEFIELD NOS CLASSIC TOWLINE ½ A CLASSIC POWER E-36/A/B ELECTRIC (COMBINED) BILL BOOTH, SR MEMORIAL
FIJ/F1P (POWER) FIG (COUPE) F1H (TOWLINE) A GAS B GAS HAND LAUNCH GLIDER (1) FULL SIZE TEXACO MULVIHILL DAWN MULVIHILL		

(1) Junior & Senior/Open Event

(2) Cash Awards

See Special Instructions on backside

**** AN ORBITEER TRADITION LIVES ON ****

JOIN US FOR SATURDAY ICE CREAM SUNDAE SOCIAL ON US (NOON – 1 PM)
also

SATURDAY NIGHT FOOD FEST POTLUCK ORGANIZED BY DAN HEINRICH (5:30 -7:00 PM)

(Main course provided)(Bring a side dish or dessert)(Let Dan know what you're bringing at aeronutd@cs.com)

AWARDS FOR FIRST 3 PLACES (except as noted)
Ceremonies at: 5:15 PM Saturday
3:15 PM Sunday

\$15 REGISTRATION Sr. & Open / \$2 Jr
\$5 per Event Sr. & Open / \$1 Junior -
Optional: \$35 for Registration & Unlimited Events

For Information Contact:

Don Bartick, CD - San Diego Orbiteers
 22465 Casa De Carol
 Ramona, CA 92065
 (H) 760-789-3773
 (E) dbartick@4-warddesign.com

David Martin, CD-Fresno GMC
 Contact: Steve Jensen
 (H) 559-291-2012
 (E) steve93612@comcast.net

LOST HILLS MODEL AIRFIELD ASSOCIATION CARD REQUIRED (\$20 AT FIELD TO JOIN)

SPECIAL INSTRUCTIONS

SATURDAY NOON to 1 PM LUNCH BREAK & SUNDAE SOCIAL

The contest will be suspended for 1 hour for lunch and the San Diego Orbiters famous ice cream social. This is a great time to relax, cool off, have lunch and enjoy the ice cream sundaes. We will provide ice cream, & sundae fixings, napkins, plates and plastic ware.

PRIZE DRAWING

The Fresno GMC once again has collected an enormous amount of model stuff for their drawing. For up to 3 events entered that are sponsored by them, the contestant will receive a drawing ticket. Drawing to be held right after Sunday's award ceremony.

TOM CARMAN MEMORIAL

Any size Texaco or Spacer. If Nostalgia legal, must fly by Nostalgia rules. If AMA legal, must fly by AMA rules. No entry fee. Event runs both days, but must be finished on the day started. Must sign up for the event. Special cards will be provided. Cash prizes 1st thru 3rd place: \$50, \$25 & \$15. Event sponsor is Jim Hurst. Questions: contact Jim at 310-324-5425.

BILL BOOTH, SR. MEMORIAL

High time in Old Time Gas. Includes 020 Replica, but not Texaco. Winner will receive a special award from the Fresno GMC.

HAND LAUNCH GLIDER & CATAPULT GLIDER

Hand Launch Glider & Catapult Glider will to be launched from an established glider pen on the field. Max's are 120 seconds and all flights count.

E36/A/B ELECTRIC

E36: 36" Max. wing span, min. weight 120 gms, 2 cell Lithium Polymer battery pack max, fixed surfaces except DT. Folding props are allowed. Hand launch flights. 6 attempts to complete 3 official 120 sec flights with 15 sec motor runs, 40 sec minimum official flight. Fly off flights have motor run reduced to 10 sec first fly off, then reduced to 5 sec and continue at 5 sec until 120 sec flight time is not achieved.

AMA A: Any number of cells of any rechargeable battery technology, fixed surfaces except DT, 6 attempts to complete 3 official 120 sec flights with 10 sec motor runs, 40 sec minimum official flight. Fly off flights have motor run reduced to 5 sec and continued at 5 sec until 120 sec flight time is not achieved.

AMA B: Same as A except variable surfaces are allowed.

NIGHT GAS FLYING

All engine classes combined. Event window between 6pm – 9pm. Engine runs in accordance with aircraft classification; i.e., AMA or Nostalgia.

DAKOTA

Target time 60 seconds. Score based on differential of actual flight time to target time. Lowest score of 3 flights combined.

MINI FAI EVENTS **Low stress format**

F1G, F1H, F1J/P: First five (5) flights must be flown from the established line between 7:00 – 12:00 AM. 120 sec max Fly-off in ½ hour rounds starting at 1:00 PM. 15min rounds in sequence. 15min between end of round and beginning of next one. Fly-off round max: 1st 150sec, 2nd 180sec, 3rd 210sec, 4th 240sec, 5th 300sec, 6th 360sec and so on. Fly-off rounds may be compressed by consensus of the participants and the CD.

VINTAGE FAI POWER **Low stress format**

For rules, please go to this website: <http://faipower.com/vintage-fai-power.htm>. A copy of the rules will be available at the CD's table. First five (5) flights must be flown from the established line between 7:00 – 12:00 AM.

DAWN P-30

Saturday morning 7:30 AM exactly, mass launch from glider pen, one flight, no max, winner's plane may be processed.

DAWN MULVIHILL (Timer can ride with contestant)

Sunday morning 7:30 – 7:50 AM launch window, one flight, no max.

TEXACO (Timer can ride with contestant)

1/2A Texaco: Saturday 7:00-10:00 AM launch window, 8cc fuel; Full Size Texaco: Sunday 6:00-10:00 AM launch window, 1/4oz per pound – max 1.75oz fuel.



HANGAR NEWS



AMA Charter #1651

Scale Flyin

Sanction 13-1241

When: **Saturday May 18, 2013**
Where: First Weedwacker Aero Squadron Field, Cactus Park
Time: Checkin 08:00 AM
Flying: 09:00 to 1:00
Landing Fee: \$10.00

Pilots Raffle and Open Raffle

Food Available

Scale and Semi-Scale Models Welcome

Awards for: Best Civilian, Military, Peoples Choice and Judges Choice

There are strict sound regulations. Engine noise cannot exceed 96 DBa @ 3 m

Sound Meter available at field.

Must show AMA card to enter.

For more information call:

Lee Main
619-258-0812

Keith Miller
keeferm@cox.net

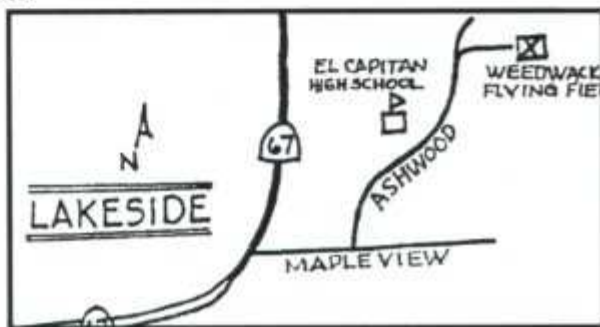

SAN DIEGO ORBITEERS
Howard L. Haupt / Editor
3860 Ecochee Avenue
San Diego, California 92117-4266

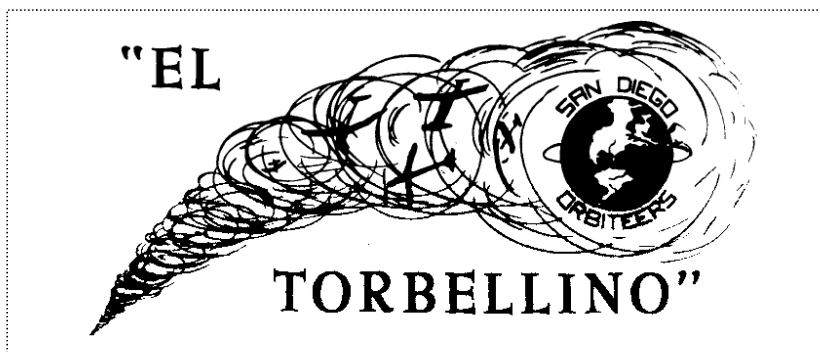

WHAT'S HAPPENING - MAY / JUNE 2013

May 18-19 **Dual Club FF Bonanza**, Lost Hills CA, See enclosed flyer.

May 18 - Weed Wackers Scale Fly-In, Cactus Park Lakeside, See enclosed flyer.

June 2 - Indoor Flying, Grossmont College (Upper Gym), 7:30 am to 11:30 am.
Feature event Penny Plane.

June 9 - **Orbiteer Outdoor Monthly**, Otay Mesa, 8:00 am.
Feature Event: Coupe Other Events: Power & Glider

June 16 - SCAMPS CONTEST, Perris CA.

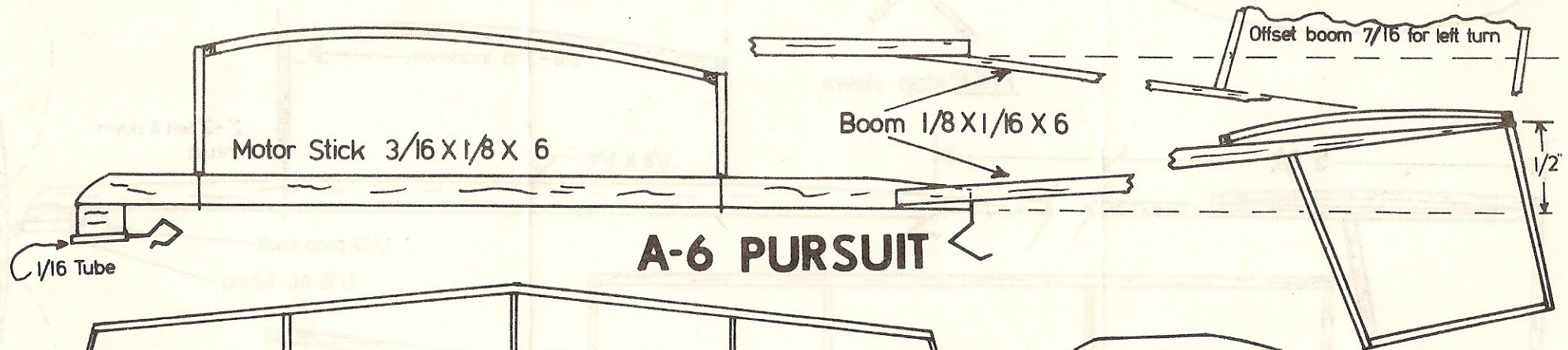
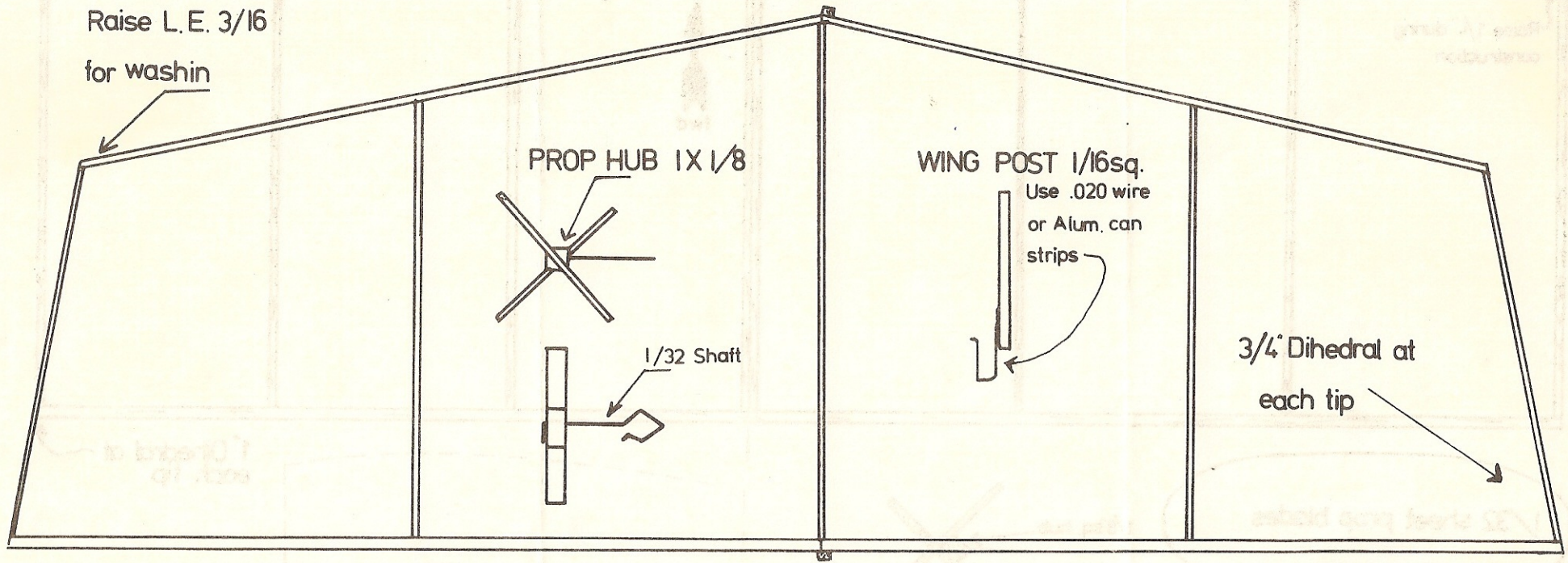

A-6 PURSUIT

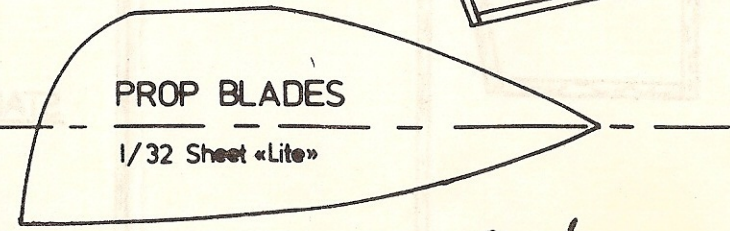
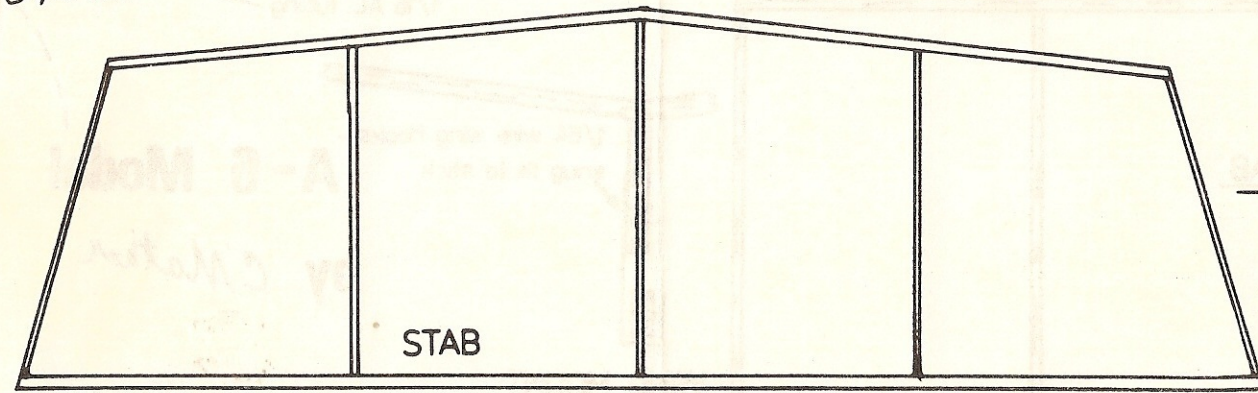

By *Aud*
Trans and 11108 64 f. f. f. f.

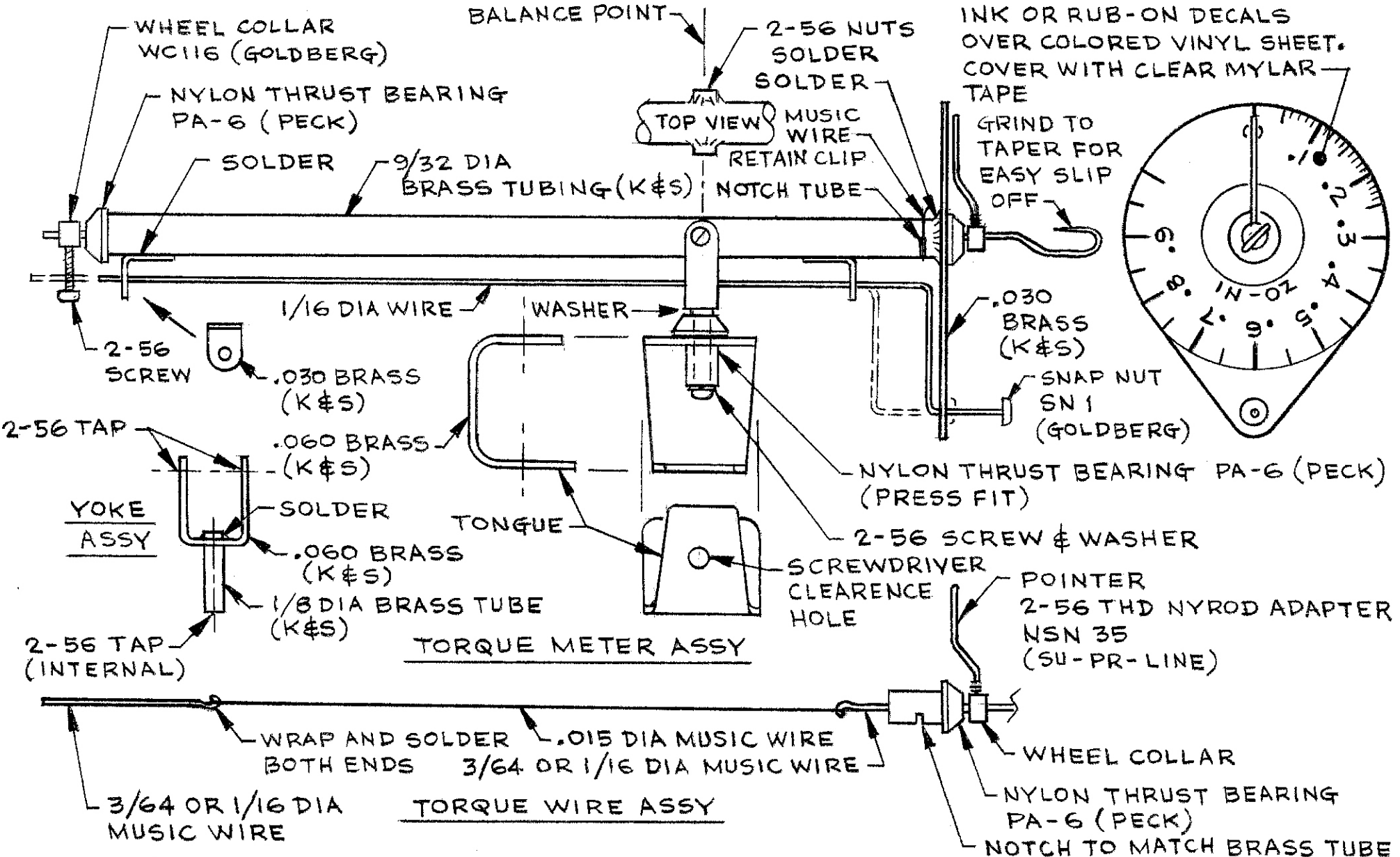

INDOOR TORQUE METER
 FROM
 HOBBY STORE MATERIALS
 DESIGN BY: CEZAR BANKS
 DRAWN BY: NAT ANTONIOLI
 SAN DIEGO ORBITEERS
 JUNE 1983

NOTE: CALIBRATE WITH KNOWN WGTS/ARMS OR AGAINST ANOTHER TORQUE METER

